



Image courtesy of California Closets. All rights reserved.

# Sliding Door Technical Manual



Element Designs is the leading manufacturer of custom aluminum frame doors in North America. All of our doors are built to our customers' specifications within 1/16". Our aluminum frame door program offers numerous profile options in several finishes and a vast selection of inserts to accent virtually any interior application. Element Designs can provide complete door systems with sliding hardware and guides/ rails cut to size, making the door installation process simple.

Our customer service, quick lead times and quality are the foundation of our company. Our nationwide network of sales representatives and distributor locations provide a superior level of support to our customers and are always available to assist you with your order.

- Sliding Doors At A Glance ..... 3
- Design Guide: Aluminum Door Profiles ..... 4
- Design Guide: Aluminum Door Inserts ..... 5
- Design Guide: Aluminum Door Divider Rail ..... 7
- Design Guide: PARAPAN Door Colors ..... 8
- Design Guide: PARAPAN Options ..... 9
- Design Guide: Decorative Hardware ..... 10
- Handle Boring Specifications ..... 11
- Large Sliding Doors CD 50 E Components & Installation Guide ..... 12
- Large Sliding Doors DN 80 CF Components & Installation Guide .... 21
- Small Sliding Doors CD 30 CX Components & Installation Guide..... 33
- Small Sliding Doors SH 7035 Components & Installation Guide ..... 42
- Warranty..... 50

	CD 50 E	DN 80 CF	SH 7035	CD 30 CX
<b>Area of Application</b>				
Closet doors	✓	✓		✓
Pantry	✓	✓		✓
Tall cabinets	✓	✓		✓
Room Divider	✓	✓		
Small cabinets			✓	✓
Furniture			✓	✓
<b>Design</b>				
Wide aluminum frame doors	✓	✓	✓	✓
Narrow aluminum frame doors			✓	
PARAPAN® doors	✓	✓	✓	✓
Weight capacity (per door) *	110 lbs (50 kg)	176 lbs (80 kg)	33 lbs (15 kg)	66 lbs (30 kg)
Door height maximum	96" **	96" **	48"	96"***
Door width maximum	N/A	N/A	36"	36"
<b>Carrier Position</b>				
Top Sliding		✓		
Floor Sliding	✓		✓	✓
<b>Door Positioning</b>				
Inset	✓	✓	✓	✓
Floor to Ceiling	✓	✓		
<b>Door Travelling</b>				
Bypass	✓	✓	✓	✓
Single Plane	✓	✓	✓	✓
<b>Tracks &amp; Guides</b>				
Track	1, 2, 3	4, 5, 6, 7	9	1, 2, 3
Guide	8	10, 11	9	1, 2, 3

Contact Element Designs for availability of other sliding hardware systems and applications.

\* Door weight calculator can be found online: [www.element-designs.com/support/](http://www.element-designs.com/support/)

\*\* Maximum door height may exceed 96" depending on insert. Please contact Element Designs.



### Frame Profiles



AF001

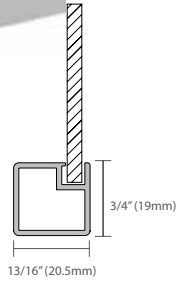

AF002

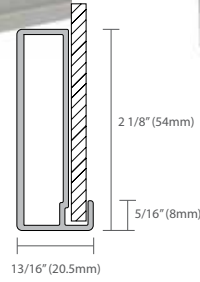

AF003

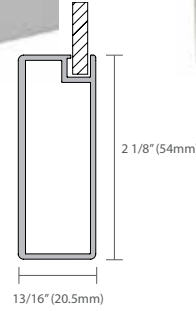

AF004

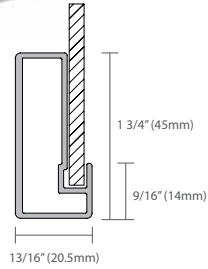

AF005

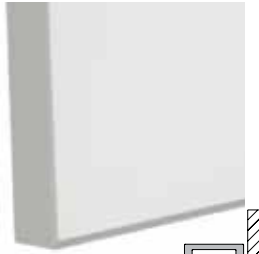
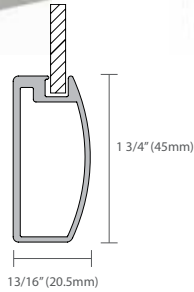

AF006

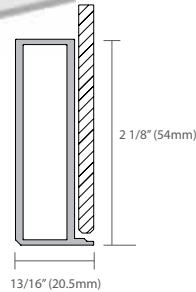

AF007



AF008

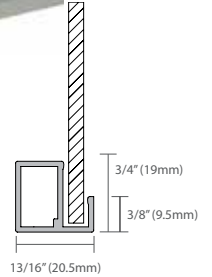

AF009

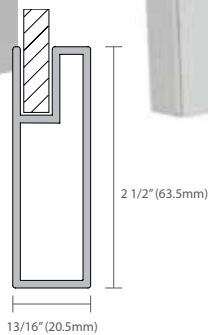

AF010

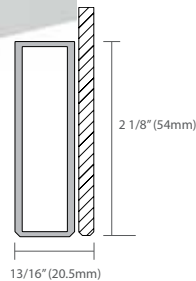

AF011

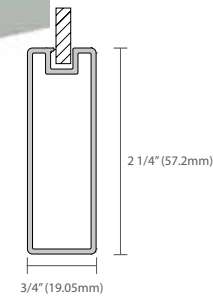

### Profile Finishes

— Anodized Aluminum —



— Powder Coat —





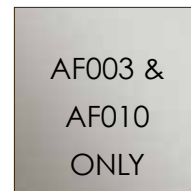





— Chrome —



— Arctic Gold —



### Standard Glass Insert Options

 satin	 clear	 reeded	 lustral D	 austral	 master carre
 low-iron satin	 low-iron clear	 smoked grey	<ul style="list-style-type: none"> <li>• Glass inserts are 5/32" (4mm) thick</li> <li>• Etched and patterned side facing in</li> <li>• Glass is tempered safety glass without tempered logo unless otherwise specified</li> <li>• 4mm mirror available upon request. Contact Element Designs for more details.</li> </ul>		

### Backpainted Glass Insert Options

 white gloss	 white matte	 black gloss	 black matte	 charcoal gloss	 charcoal matte
 sand gloss	 sand matte	 olive gloss	 olive matte	 mocha gloss	 mocha matte
 scarlet gloss	 scarlet matte	 silver gloss*	 silver matte*	 bronze gloss*	 bronze matte* *metallic

- High quality water based paint on low iron glass
- All glass is tempered safety glass without a tempered logo unless otherwise specified
- 177 Non-Standard and Custom colors available.
- All backpainted glass has a light grey backer for added durability

### High Gloss PARAPAN® Insert Options



- High gloss solid surface PARAPAN® material
- PARAPAN® inserts not available with AF006 or AF010
- Inserts are 5/32" (4mm) thick
- UV and fade resistant
- Easy to clean and water resistant

Images may not be exact representations of solid surface color options. Contact Element Designs to obtain samples.

- Complimentary cleaner provided with orders

### 3form Architectural Resin Insert Options



- Inserts are 5/32" (4mm) thick
- Sandstone finish on front and back
- Resin inserts contain organic materials and may vary in color and density due to natural conditions

### Metallic Insert Options



- Inserts are 5/32" (4mm) thick
- Platinum ice acrylic not available with AF006 or AF010



### Divider Rail

- Divider rails can be used with large sliding doors to provide additional design options
- Contact Element Designs for panel height and width limitations with integrated divider rails
- Multiple inserts may be used per door with divider rail
- Rail measures 25/32" (20mm) wide
- For use with the following profiles:

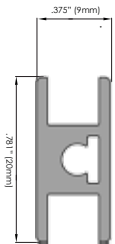

- AF001
- AF003
- AF005
- AF007
- AF009
- AF011





### Color Options

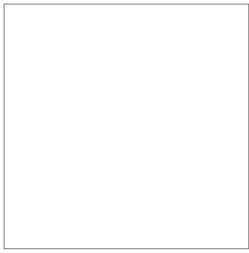

alpine white 5910

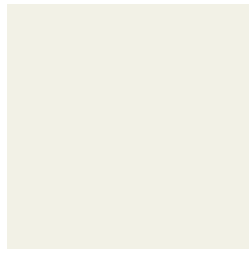

white 5907



opal white 5196

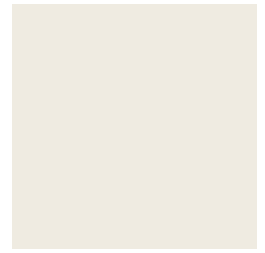

latte 5772



pale ivory 5525

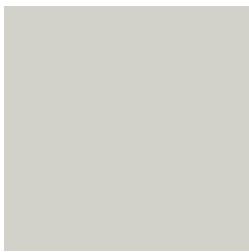

light grey 5290



stone grey 5295



cappuccino 5773

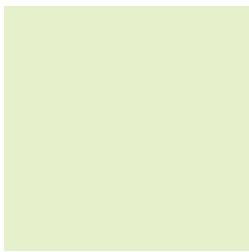

mint 5421



kiwi 5440



turquoise 5471



cobalt blue 5380



orange 5570

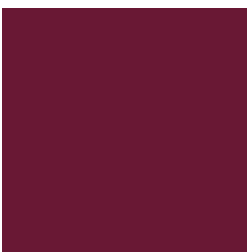

bordeaux 5600



signal red 5655

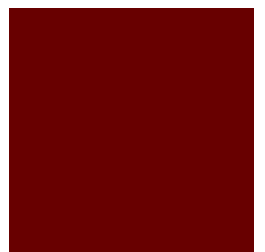

oxide red 5771

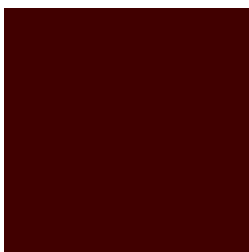

brown 5776

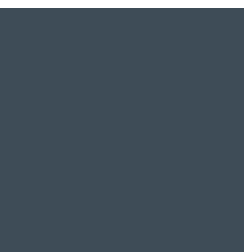

anthracite\* 5297

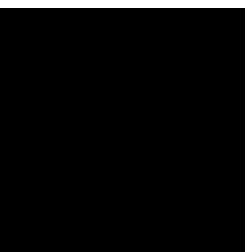

black 5299

Images may not be exact representations of solid surface color options. Contact Element Designs to obtain samples.

\* Only available in 18mm thickness.



### Edge Radius Options

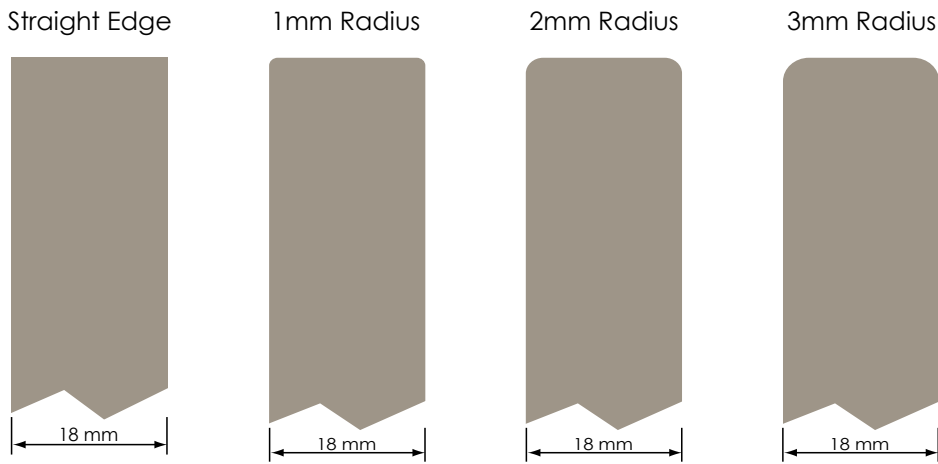

### Integrated Pulls

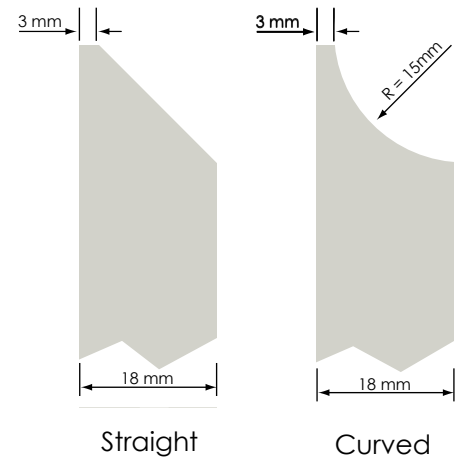

- All six surfaces have high gloss finish
- Functional and decorative hardware borings will be predrilled per specification
- Available in 19 colors
- Only available as finished doors and panels
- 4mm solid surface panels available in full sheets or cut to size for cabinet cladding and appliance applications
- PARAPAN 18mm doors are available with a choice of two standard integrated pull options
- Contact Element Designs for availability of additional custom integrated finger pull shapes

Door weight calculator can be found online: [www.element-designs.com/support/](http://www.element-designs.com/support/)



### Natural Aluminum Finish Knobs



K001



K005



K006



K007



K008



K009

### Handles & Pulls

natural aluminum finish



available lengths:

- P1-127 Length: 7 3/8" (5" c. to c.)
- P1-190 Length: 9 13/16" (7 1/2" c. to c.)
- P1-250 Length: 12 13/16" (9 13/16" c. to c.)
- P1-380 Length: 17 5/16" (14 15/16" c. to c.)
- P1-640 Length: 27 9/16" (25 3/16" c. to c.)
- P1-880 Length: 37" (34 5/8" c. to c.)

brushed stainless steel look finish



available lengths:

- P1-76S Length: 5 5/16" (3" c. to c.)
- P1-192S Length: 9 15/16" (7 9/16" c. to c.)
- P1-320S Length: 15" (12 9/16" c. to c.)

oil rubbed bronze finish



available lengths:

- P1-76ORB Length: 5 5/16" (3" c. to c.)
- P1-192ORB Length: 9 15/16" (7 9/16" c. to c.)
- P1-320ORB Length: 15" (12 9/16" c. to c.)

### Finger Pulls



P2-42  
Length: 3" (2" c. to c.)  
natural aluminum finish



Also available in black, white and oil rubbed bronze powder coated finishes



**P2-42 pulls also available in custom lengths. Contact Element Designs for details.**

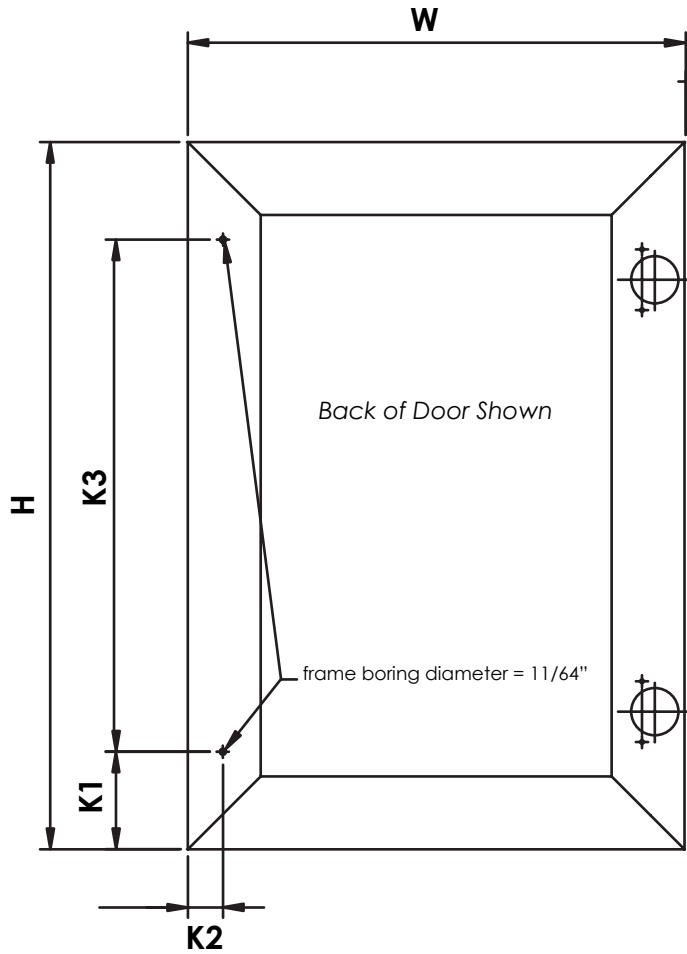

Profile	K1 Standard (Knob/ Pull Center from door edge)	K1 Minimum (Knob/ Pull Center from door edge)	K2 Standard (centered on profile)	Std. Handle Boring Location Through Glass (If yes, customer MUST specify hole location at time of order)
AF001	2.5" (63.5mm)	2"	.375"	NO
AF002	2.5" (63.5mm)	2.25"	1.063"	<b>YES</b>
AF003	2.5" (63.5mm)	2.25"	1.063"	NO
AF004	2.5" (63.5mm)	2.25"	.875"	<b>YES</b>
AF005	2.5" (63.5mm)	2.25"	.875"	NO
AF006	2.5" (63.5mm)	2.25"	.875"	<b>YES</b>
AF007	2.5" (63.5mm)	2.25"	1.375"	NO
AF008	22.5" (63.5mm)	2"	Contact Element Designs	<b>YES</b>
AF009	2.5" (63.5mm)	2.25"	.875"	NO
AF010	2.5" (63.5mm)	2.25"	.844"	<b>YES</b>
AF011	2.5" (63.5mm)	2.25"	1.125"	NO

- Standard Aluminum Handle Boring Diameter = 11/64" (4.3mm)
- Standard Glass Handle Boring Diameter = 5/16" (8mm)

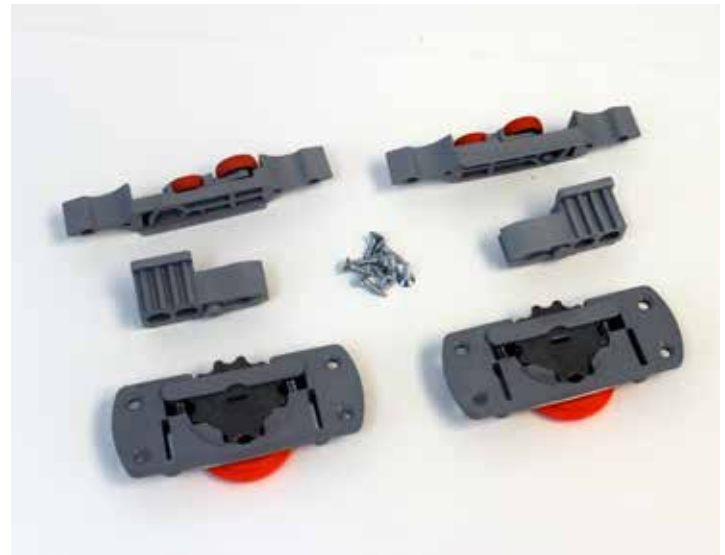

## CD 50 E

### Design Guidelines:

- Floor Sliding System, top guide and bottom track
- Multiple doors per system, inset or surface mount track
- Floor to ceiling and inset casework applications
- Reference Sliding Systems At A Glance for maximum door dimensions
- Doors weighing up to 110 lbs

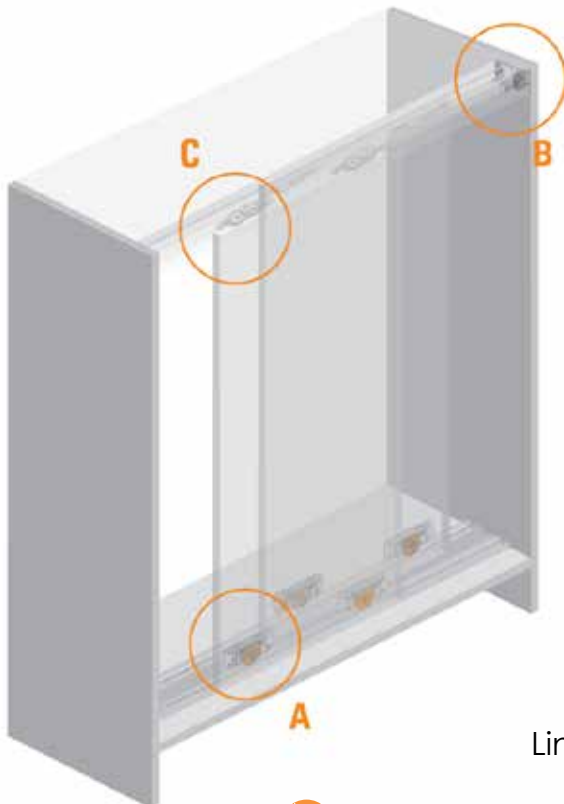

Bottom Load Bearing  
Roller System  
(2 per door - preinstalled)



Adjustable Position  
Door Stops

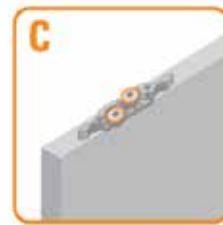

Top Door Guides  
(2 per door - Soft Close  
mechanisms available)

Link to Sliding Hardware Video: <https://vimeo.com/94243233>

Optional Soft Close Mechanism (Soft Close GOR):  
<https://vimeo.com/81816626>



**Application Type:** LARGE sliding door applications (floor to ceiling, closets / wardrobes, interior openings)

**Tracks & Guides:** Surface mount or inset floor track, double top guide

**Frame height minimum:** 35mm (1.38")

**Planes of Travel:** multiple doors on multiple planes of travel

**FEATURES AND BENEFITS**

- Stoppers with retention device installed inside track maintain door position
- Spring activated carrier provides a dynamic adjustment to the floor
- Easy to install doors. Central adjusting dial allows for easy height regulation
- Ball bearing high quality rollers for a silent and smooth movement
- Soft close mechanisms available

**DESIGN GUIDELINES**

**Door weight max:** 50kg (~110 lbs)

**Recommended Door height max:** 96" (contact Element Designs for taller dimensions)

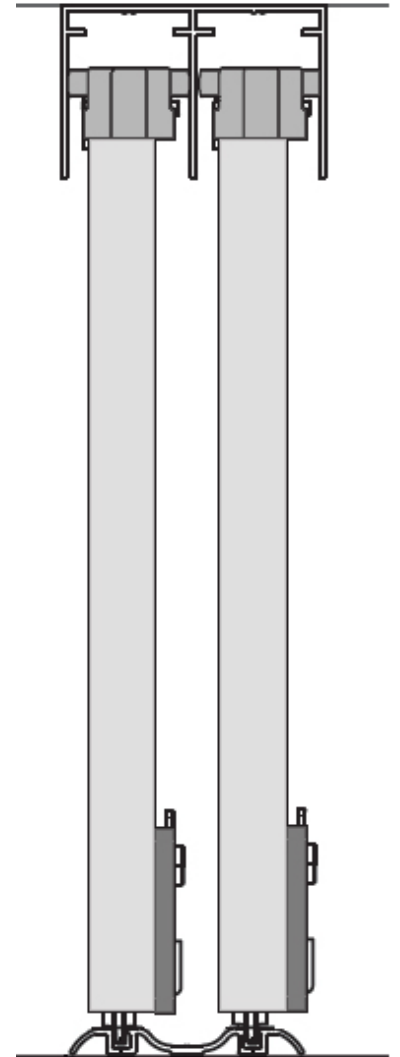

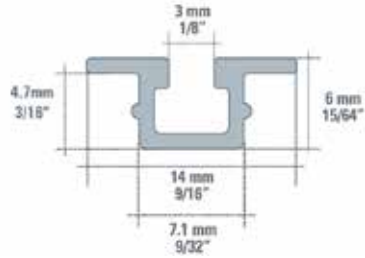
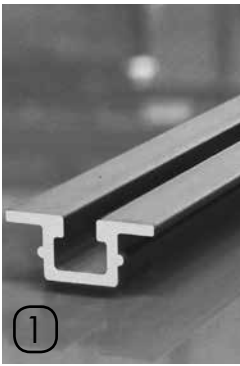

Inset Single Track (021CXE)

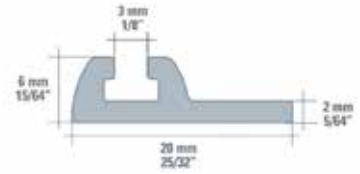
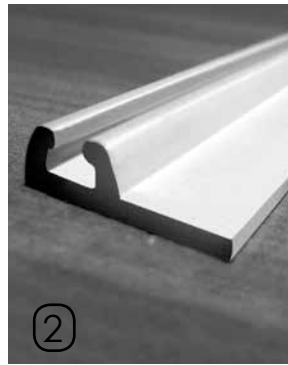

Surface Mount Single Track (021CX)

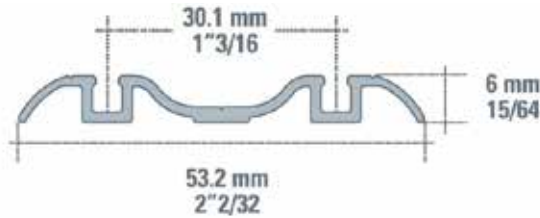
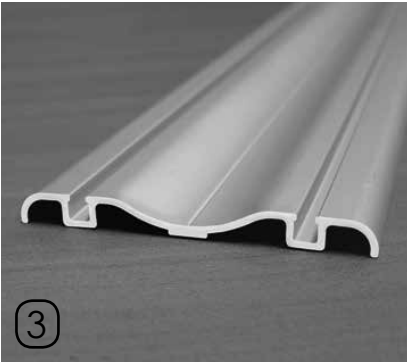

Surface Mount Double Track (021CXD)

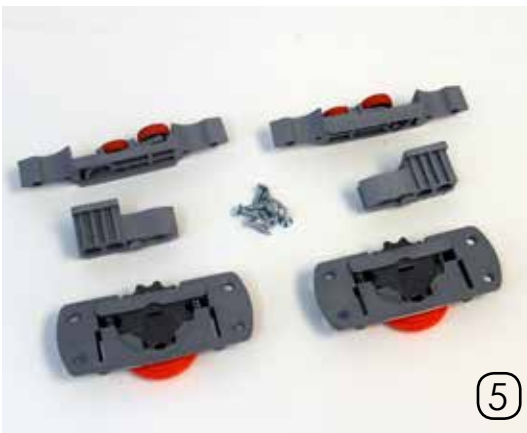
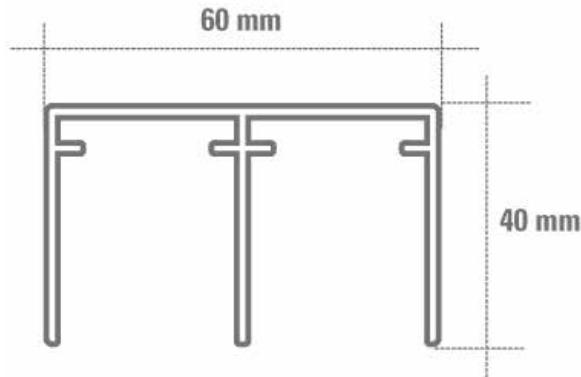

- 1) Inset Single Track (021CXE)
- 2) Surface Mount Single Track (021CX)
- 3) Surface Mount Double Track (021CXD)
- 4) Top Guide Double (GO22)
- 5) Carrier Kit
- 6) Soft Close Mechanism - Easy Soft GOR

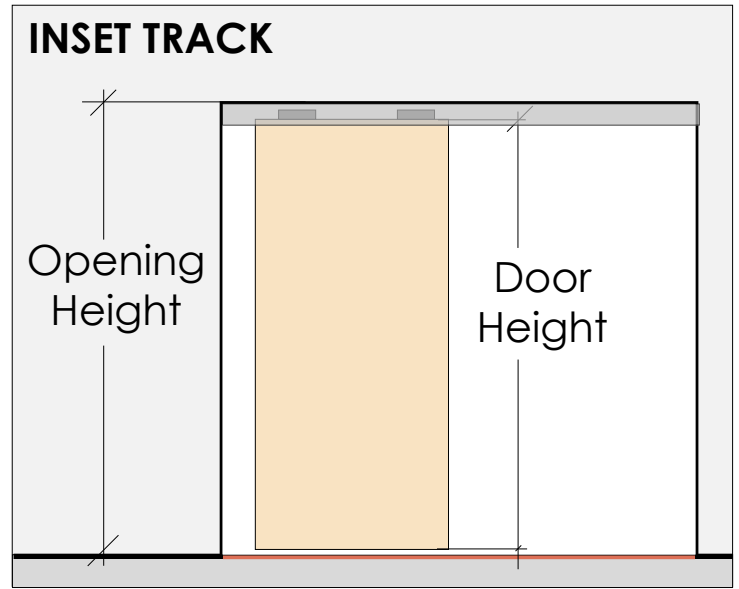
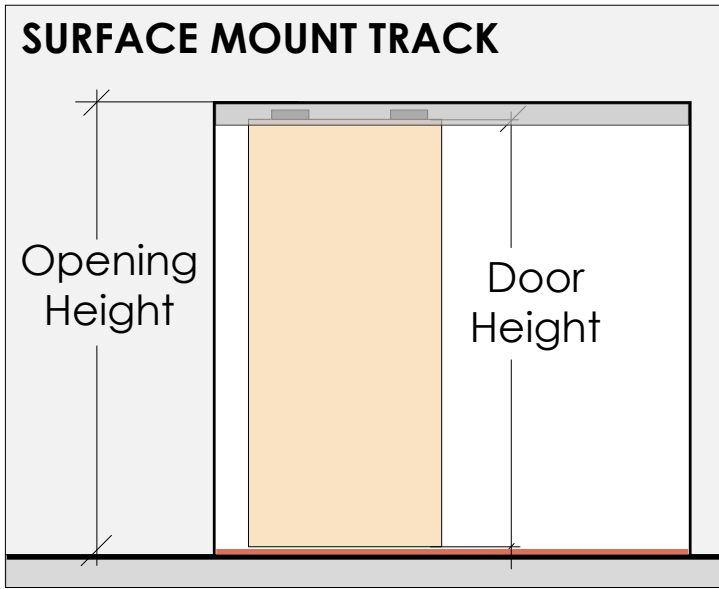

**SURFACE MOUNT TRACK:**  
 Door Height = Opening Height - 40mm

**INSET TRACK:**  
 Door Height = Opening Height - 35mm

$$\text{Door Width} = (\text{Opening width} \div \# \text{ of doors}) + (\text{profile width}^* \div 2)$$

\*Profile Width:

- |                       |                       |                       |                         |                       |
|-----------------------|-----------------------|-----------------------|-------------------------|-----------------------|
| AF002 = 2 1/8" (54mm) | AF004 = 1 3/4" (45mm) | AF006 = 1 3/4" (45mm) | AF009 = 2 1/2" (63.5mm) | AF011 = 2 1/4" (57mm) |
| AF003 = 2 1/8" (54mm) | AF005 = 1 3/4" (45mm) | AF007 = 2 3/4" (70mm) | AF010 = 2 1/8" (54mm)   |                       |



**IMPORTANT:** Must install brake in top guide with clip facing inward BEFORE installing guide into opening.

### Brake Orientation

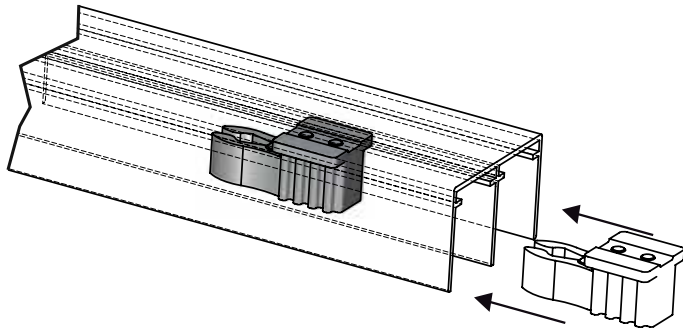

### Top Door Guide Installation

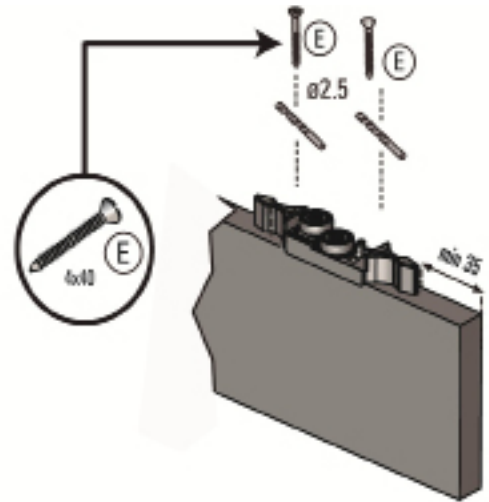

### Screw Location Spacing

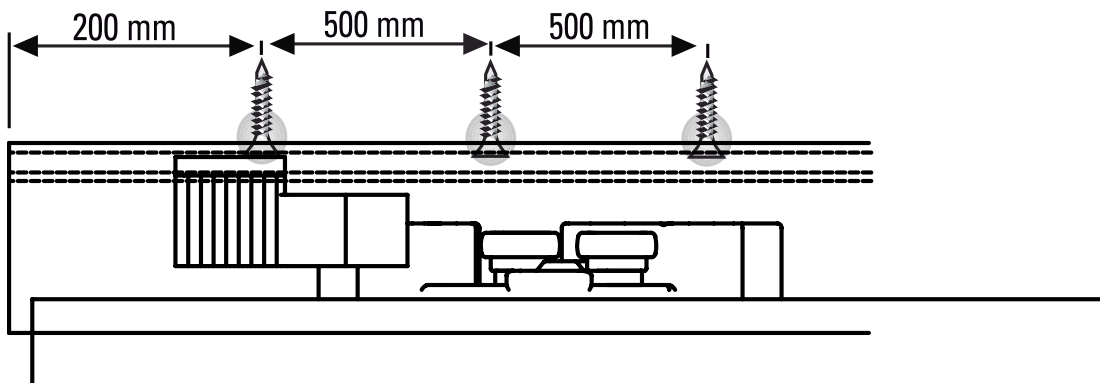

### Screw Installation Pattern

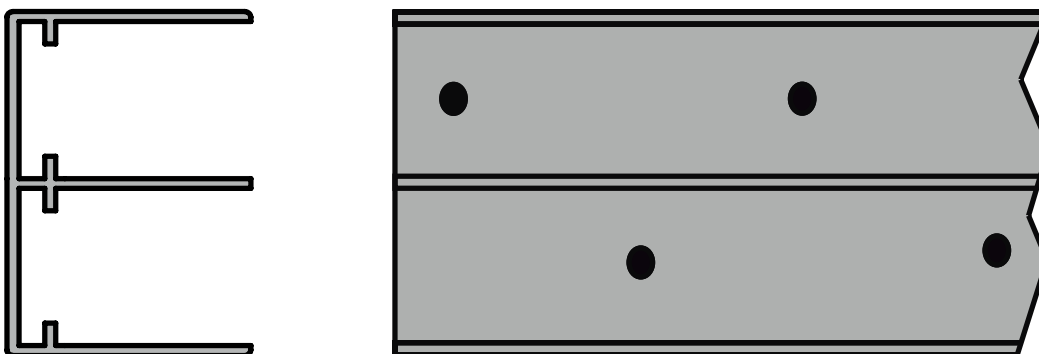

### Track and Guide Placement

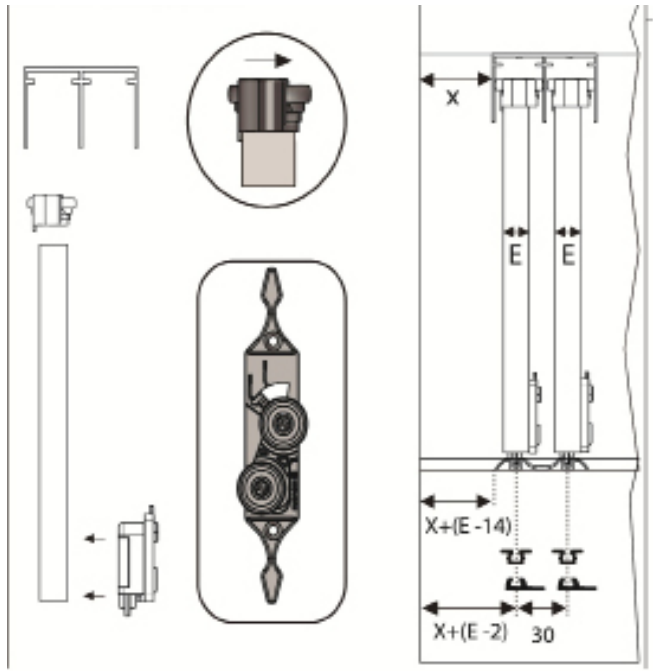

### Door Installation

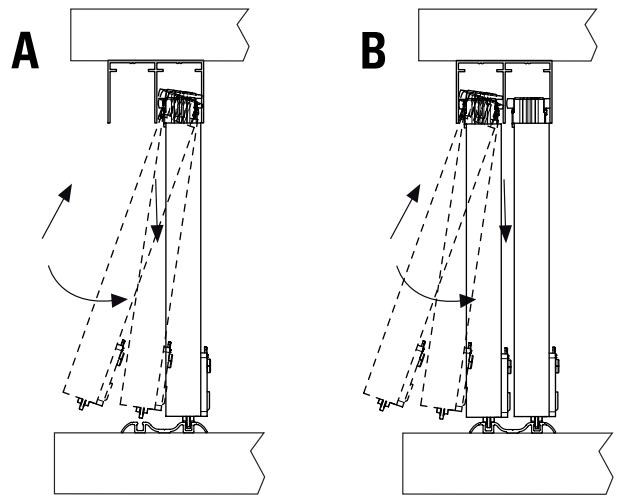

### Floor Carrier Adjustment

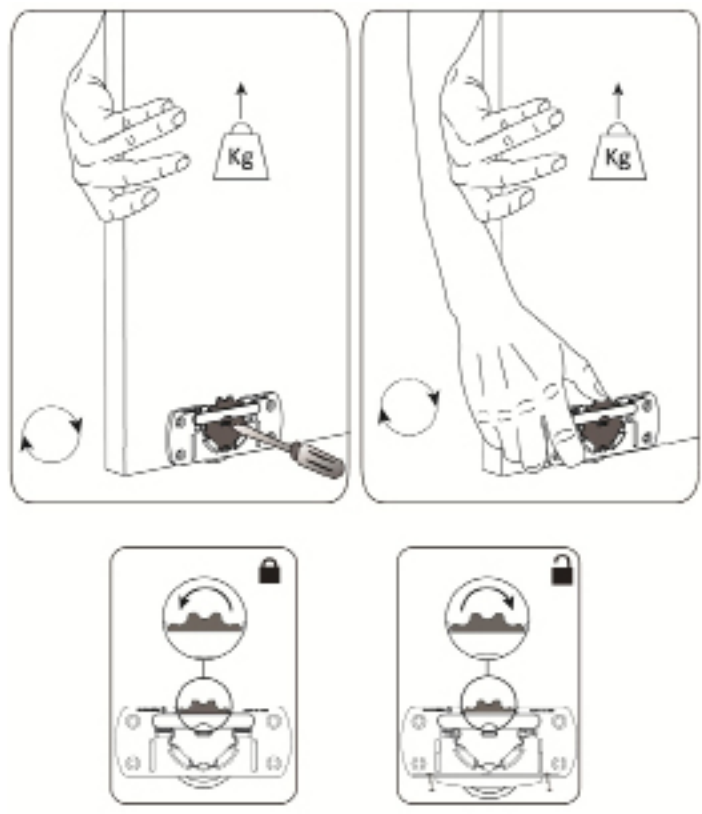



# CD 50 E Sliding Door System Quote Order

Company: \_\_\_\_\_  
 Contact Name: \_\_\_\_\_  
 Address: \_\_\_\_\_  
 City / State / Zip: \_\_\_\_\_  
 Phone #: \_\_\_\_\_  
 Fax #: \_\_\_\_\_  
 Email: \_\_\_\_\_

**Email (or fax) form to your authorized distributor:**

Authorized Distributor: \_\_\_\_\_  
 Branch Location: \_\_\_\_\_  
 Email / Fax: \_\_\_\_\_



Ph: (877) 332-3396 Fx: (704) 332-3267  
 www.element-designs.com orders@element-designs.com

Project Name: \_\_\_\_\_  
 Date: \_\_\_\_\_ PO #: \_\_\_\_\_

### ① Door Type

- Aluminum Frame:
  - AF002  AF003
  - AF004  AF005
  - AF006\*  AF007
  - AF009  AF010\*

\*AF006 & AF010 available ONLY with opaque Backpainted Glass inserts

- 18mm PARAPAN®
  - Color: \_\_\_\_\_

### ② Profile Finish

(Aluminum Frame doors only)

- Anodized Finish
  - Natural Anodized
  - Brushed Stainless
  - Chrome (AF003 & AF010 ONLY)
  - Arctic Gold (AF003 ONLY)

- Powder Coat Finish
  - Oil Rubbed Bronze
  - White  Black

### ③ Opening Info

Dimensions of space where doors will be installed, used to calculate door dimensions. Use smallest height to calculate door height.

Height (Left): \_\_\_\_\_  
 Height (Center): \_\_\_\_\_  
 Height (Right): \_\_\_\_\_  
 Width: \_\_\_\_\_

### ④ Insert Type (select one)

- Standard Glass Inserts:
  - Satin (Acid Etched)  Lustral D  Reeded (Vertical)
  - Clear  Austral  Reeded (Horizontal)
  - Smoked  Master Carre
  - Low Iron Clear  Low Iron Satin (Acid Etched)

- Backpainted Glass Inserts:

Finish (select one):

- Gloss  Matte

Color (select one):

- White  Scarlett  Silver
- Black  Olive  Bronze
- Sand  Mocha  Charcoal
- Non-Standard Color: \_\_\_\_\_
- Custom Color\*: \_\_\_\_\_

\*Custom Color match approval & fee applies. Contact Element Designs for details.  
 \*\*Backpainted glass has a light gray backer, unless otherwise specified

- 3form® Resin Inserts:

- Pattern: \_\_\_\_\_

- Parapan® High Gloss Inserts:

- Color: \_\_\_\_\_

- Metallic Inserts:

- Aluminum Laminate  Stainless Lam. (Vertical)
- Platinum Ice Acrylic  Stainless Lam. (Horizontal)

- Custom Etch:

- Positive Etch  Negative Etch
- \*Art work must be supplied, subject to set up fee. Contact Element Designs for details.

- NO INSERT all inserts are 5/32" (4mm) thick

All glass is tempered safety glass & will not have etched tempered logo unless otherwise specified at time of order. Refer to local building codes.

### ⑥ Sliding Hardware Selection

See CD 50 E technical manual for hardware specifications

#### A. Floor Track (select one)

- Inset - single only
- Surface Mount - single only
- Surface Mount - double only
- Surface Mount - single & double

#### B. Planes of Travel & Number of Doors

- 1 Plane - 1 Door
- 2 Planes - 2 Doors
- 2 Planes - 3 Doors
- 2 Planes - 4 Doors
- 3 Planes - 3 Doors

#### C. Top Guide Finish

- Natural Anodized  Oil Rubbed Bronze
- \*Brushed Stainless not available  White  Black

#### D. Soft Close\*

- Do not include
- ONE mechanism per door - LEFT SIDE
- ONE mechanism per door- RIGHT SIDE
- TWO mechanisms per door- LEFT AND RIGHT

\*Minimum door width of 20" for one mechanism, 36" for two mechanisms

One Carrier Kit per door will be included and preinstalled on each door, unless otherwise noted.

### ⑤ Decorative Hardware

Natural Anodized		Brushed Stainless & ORB	Various Finishes
Knobs	Bar Pulls	Bar Pulls	Finger Pulls
<input type="checkbox"/> K001	<input type="checkbox"/> P1-127	<input type="checkbox"/> P1-76S	<input type="checkbox"/> P2-42
<input type="checkbox"/> K005	<input type="checkbox"/> P1-190	<input type="checkbox"/> P1-192S	<input type="checkbox"/> P2-42S
<input type="checkbox"/> K006	<input type="checkbox"/> P1-250	<input type="checkbox"/> P1-320S	<input type="checkbox"/> P2-42ORB
<input type="checkbox"/> K007	<input type="checkbox"/> P1-380	<input type="checkbox"/> P1-76ORB	
<input type="checkbox"/> K008	<input type="checkbox"/> P1-640	<input type="checkbox"/> P1-192ORB	
<input type="checkbox"/> K009	<input type="checkbox"/> P1-880	<input type="checkbox"/> P1-320ORB	

QTY: \_\_\_\_\_  Drill for handle holes  
 (Must specify handle location on pg 2)

Item	Qty	Dimensions (See pg 2)		in OR mm	Divider Rails		Element Designs Use Only	
		Width	Height		(See Page 2)	Qty	Price	Ext. Price
1					<input type="checkbox"/> yes			
2					<input type="checkbox"/> yes			
3					<input type="checkbox"/> yes			

Special Instructions: \_\_\_\_\_

Knobs/Pulls : \_\_\_\_\_  
 Hardware : \_\_\_\_\_  
 Shipping : \_\_\_\_\_  
 TOTAL : \_\_\_\_\_



# CD 50 E Sliding Door System

Quote

Order

## Door Dimension Calculation:

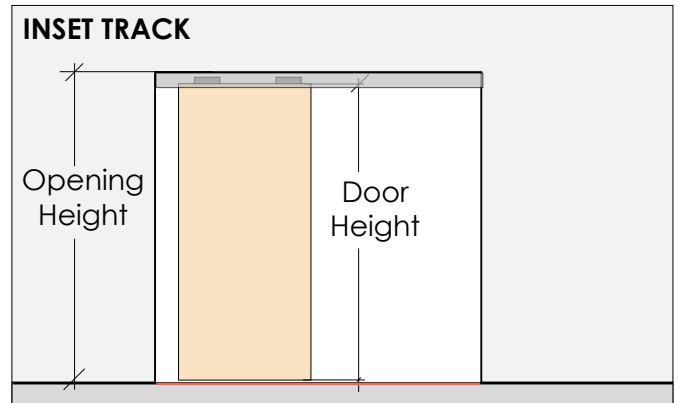
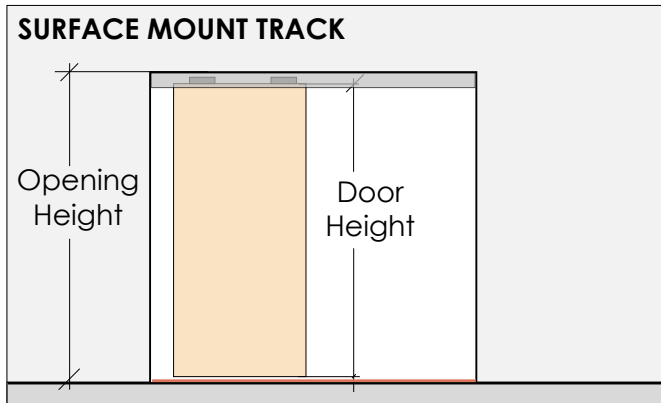

**SURFACE MOUNT TRACK:**  
 Door Height = Opening Height - 40mm

**INSET TRACK:**  
 Door Height = Opening Height - 35mm = Door

Door Width = (Opening width ÷ # of doors) + (profile width\* ÷ 2)

\*See Element Designs catalog for profile width dimensions

## Divider Rail Inserts & Locations:

\*ONLY available with AF003, AF005, AF007, & AF009. Width = 3/4"

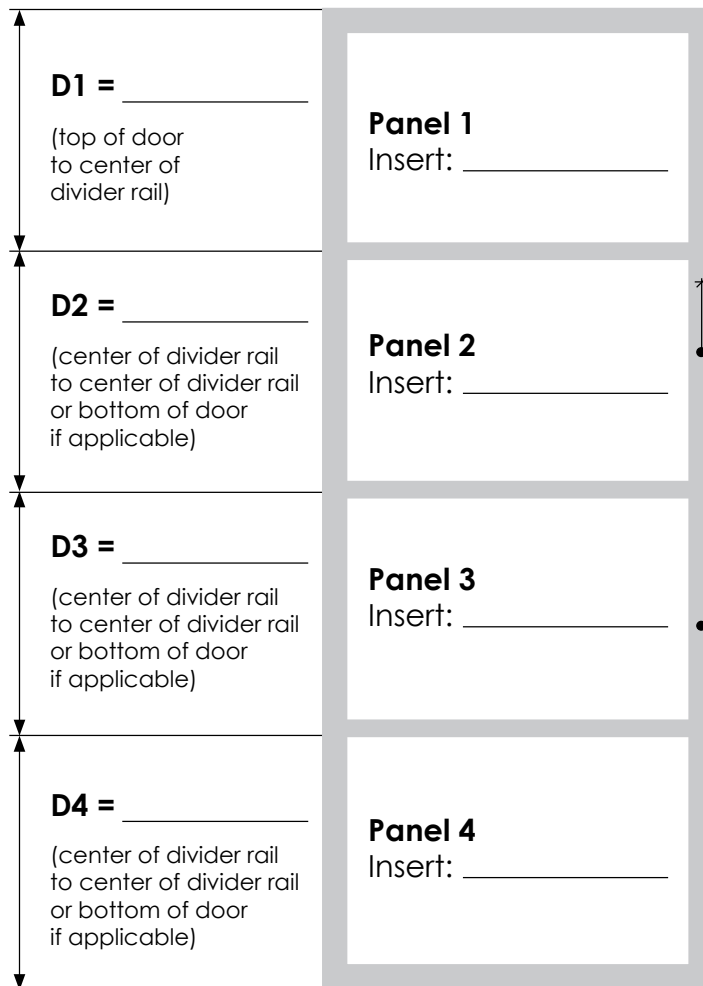

## Handle Location:

Handle Hole Diameter = 11/64" (4.37mm)

\*For handle holes in glass, the white plastic grommet cover included with the door should be left in place when handle or knob hardware is installed.

**K1 =** \_\_\_\_\_  
 Knob or Pull  
 (Std = centered on frame)

**KC =** \_\_\_\_\_  
 Center to center

**K2 =** \_\_\_\_\_  
 Knob or Pull  
 (Min = 2 1/4", Std = 2 1/2")

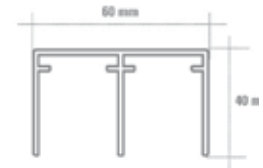

Top Guide (G22)

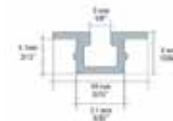

Inset Track (CXE)

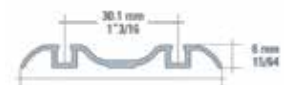

Surface Mount Track Double (CXD)



Surface Mount Track Single (CX)



## DN 80 CF

### Design Guidelines:

- Top Sliding System, top track with floor guides
- Floor to ceiling, inset casework, & barn door applications
- Recommended for use with two doors
- Reference Sliding Systems At A Glance for maximum door dimensions
- Doors weighing up to 176 lbs

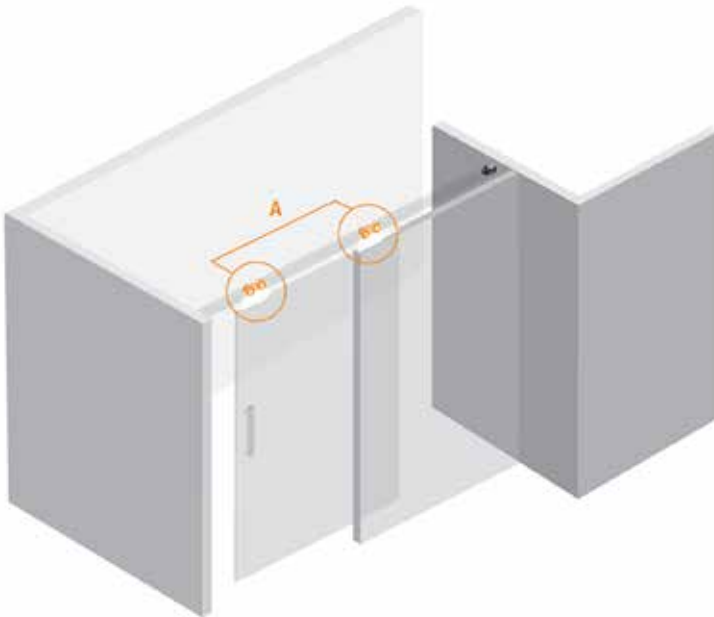

DN 80 CF System

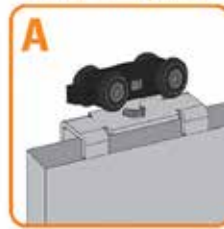

Top Load Bearing Carriers  
(2 per door - preinstalled)

Adjustable Position Door Stops

Plane of Travel Floor Guides

Link to Sliding Hardware Video (Easy Soft DN80): <https://vimeo.com/82307566>



**Application Type:** LARGE sliding door applications (floor to ceiling, closets / wardrobes, interior openings)

**Tracks & Guides:** Inset top track, barn door wall bracket, floor guides

**Frame height minimum:** 35mm (1.38")

**Planes of Travel:** multiple doors on multiple planes of travel

**FEATURES AND BENEFITS**

- Stoppers with retention device installed inside track maintain door position
- Easy to install doors. Central adjusting dial allows for easy height regulation
- Ball bearing high quality rollers for a silent and smooth movement
- Soft close mechanisms available

**DESIGN GUIDELINES**

**Door weight max:** 80kg (~176 lbs)

**Recommended Door height max:** 96" (contact Element Designs for taller dimensions)

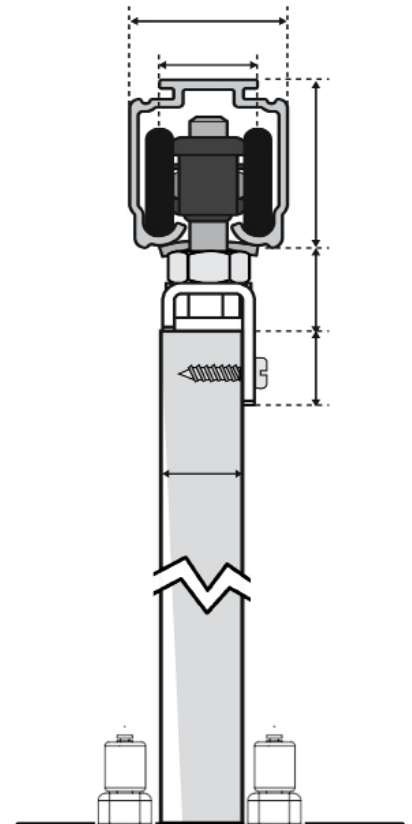

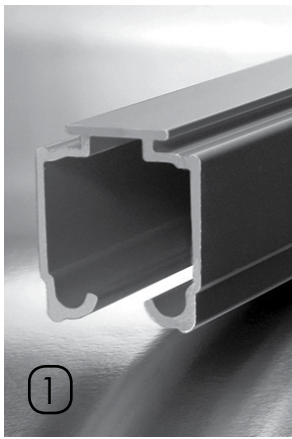

Single Track

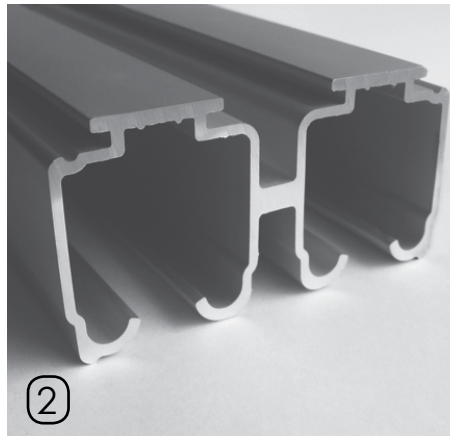
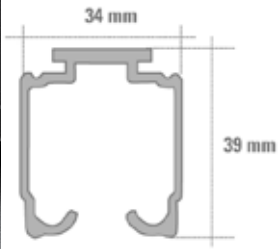

Double Track

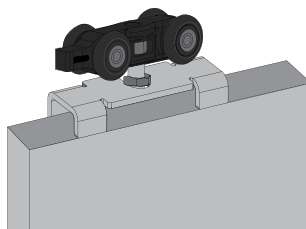
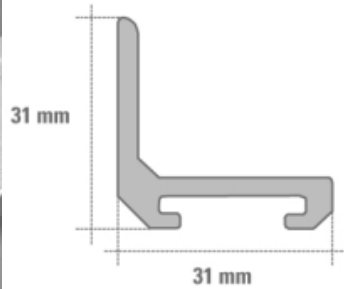
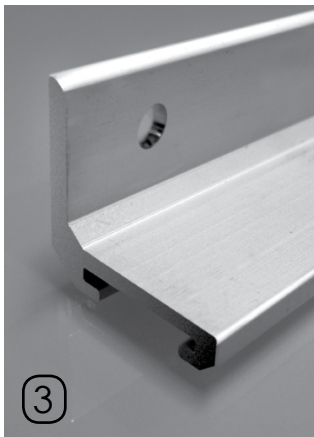
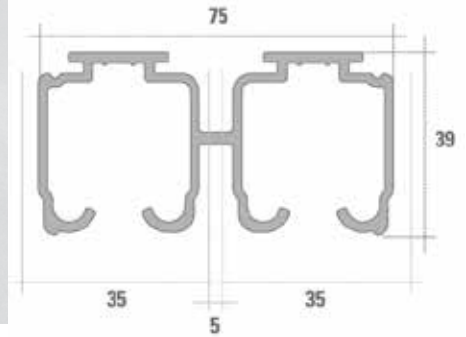

- 1) Top Hanging Single Track (U21)
- 2) Top Hanging Double Track (U21 DBL)
- 3) Lateral Wall Bracket (023BRAU21)
- 4) Top Hanging Fascia (U21 66)
- 5) Carrier Kit DN 80 CF
- 6) Round Floor Guide (GPR1150)
- 7) 'L' Bracket Floor Guide (LBR)
- 8) Easy Soft DN 80 (Optional)

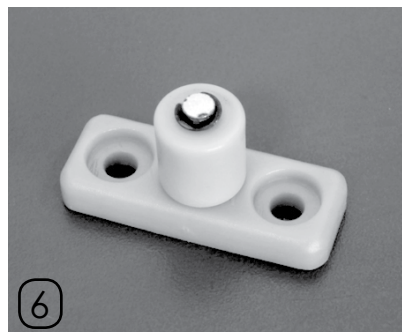



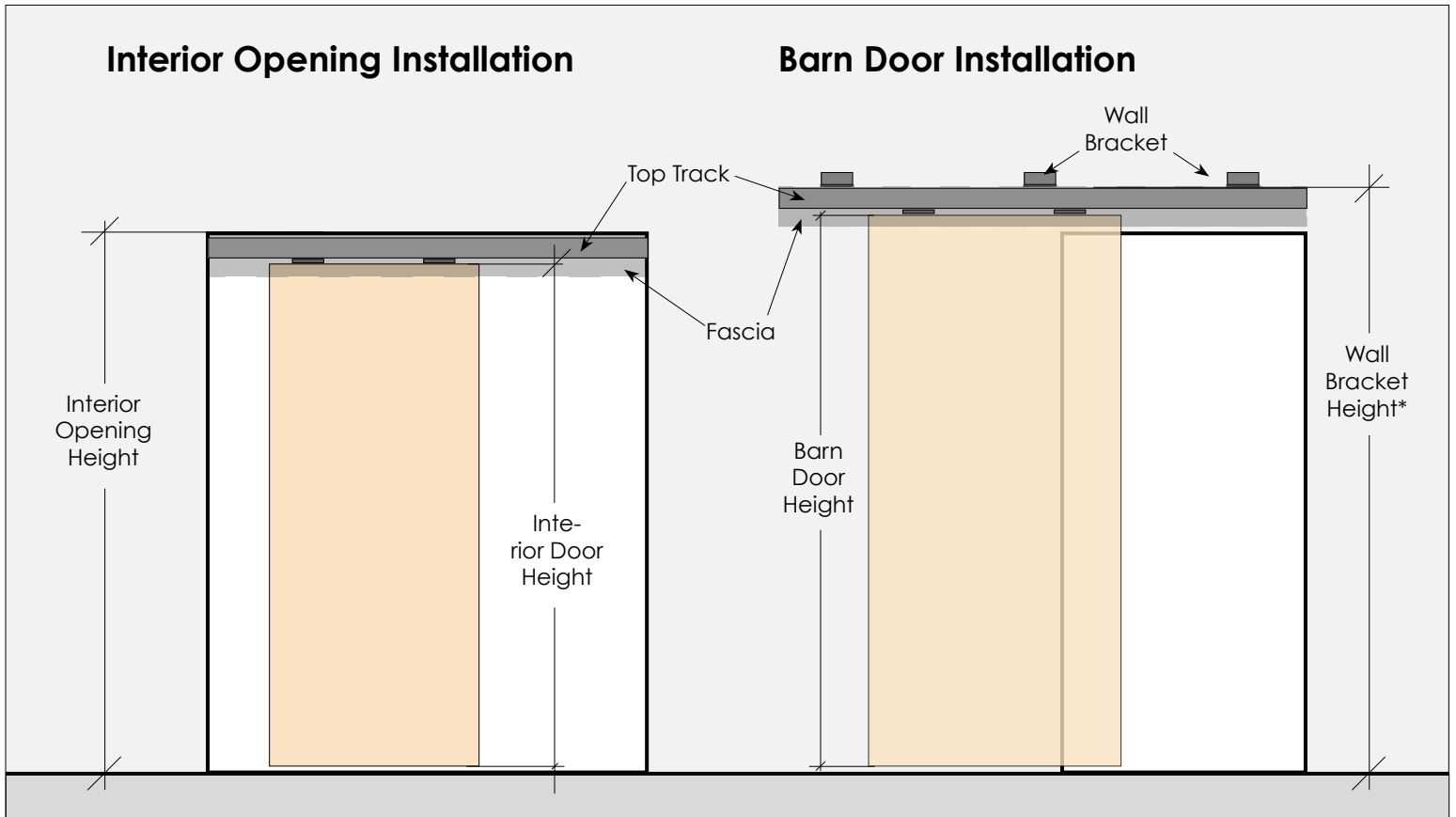

### Door Dimension Calculations:

#### Interior Opening Installation:

Interior Door Height = Opening Height - 66mm

Door Width = (Opening width ÷ # of doors) + (profile width\* ÷ 2)

#### Barn Door Installation:

Barn Door Height = Wall Bracket Height\* - 66mm

\*Wall Bracket Height measured from the BOTTOM of the bracket

\*Profile Width:

AF002 = 2 1/8" (54mm)  
AF003 = 2 1/8" (54mm)

AF004 = 1 3/4" (45mm)  
AF005 = 1 3/4" (45mm)

AF006 = 1 3/4" (45mm)  
AF007 = 2 3/4" (70mm)

AF009 = 2 1/2" (63.5mm)  
AF010 = 2 1/8" (54mm)

AF011 = 2 1/4" (57mm)



### Carrier Kit Installation:

**Carrier kit and stops must be installed in track prior to installation!**

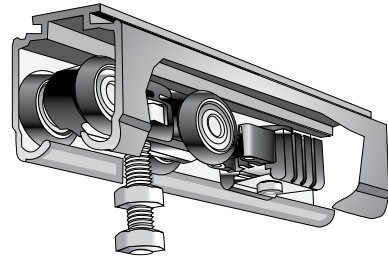

### Track Placement:

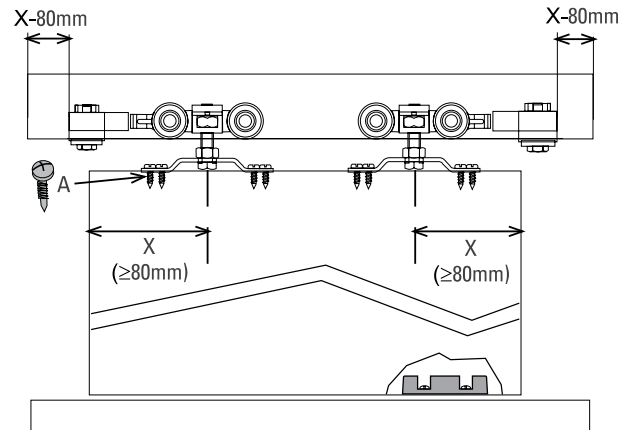
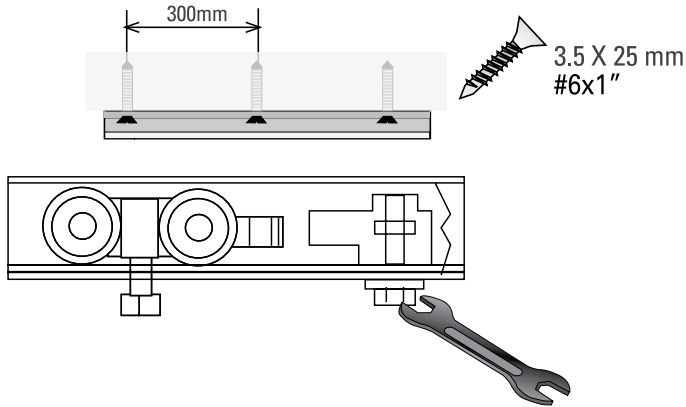

### Floor Guide Installation:

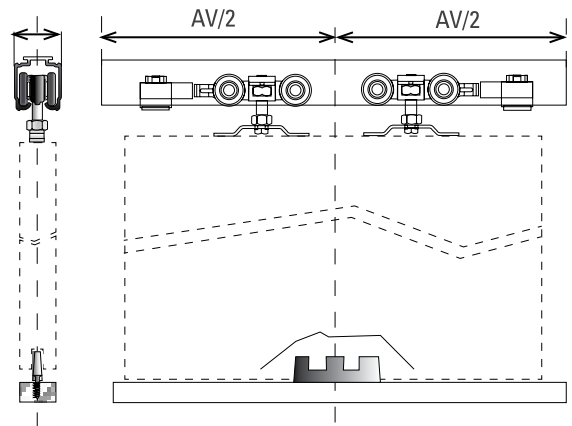
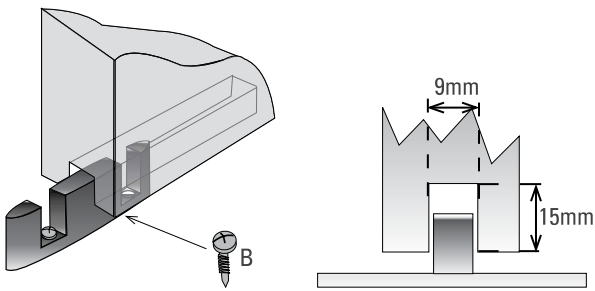

### Door Installation:

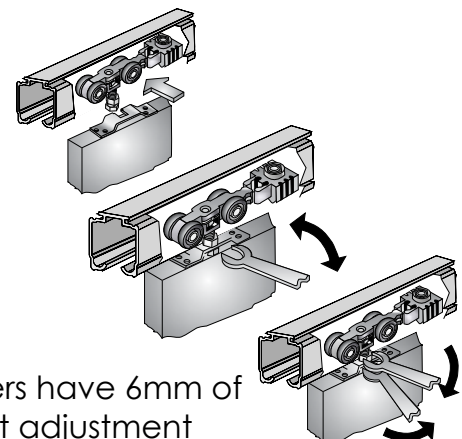
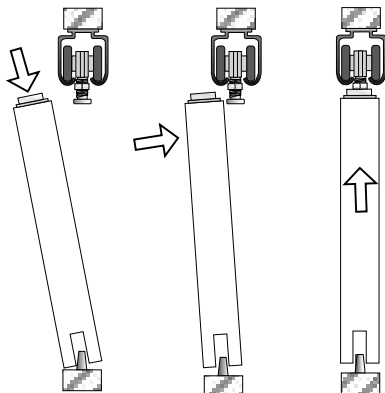

Carriers have 6mm of height adjustment

### Barn Door Track Installation:

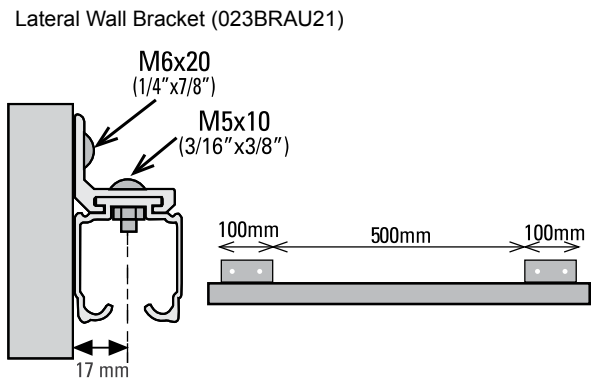

### Fascia Installation:

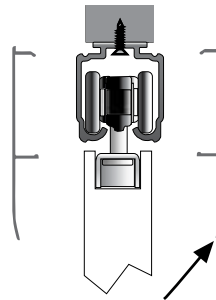

Fascia 62

### Double Track Installation:

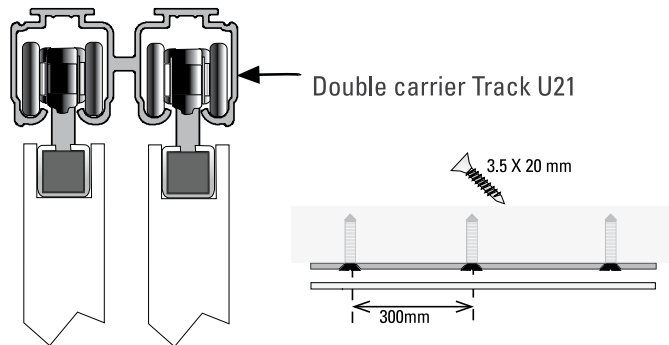

### End Caps:

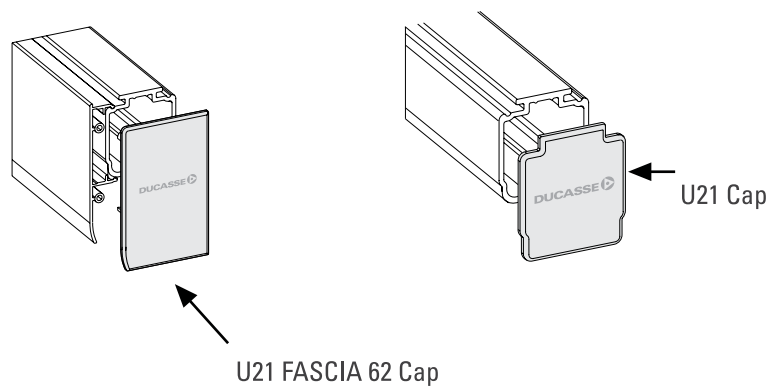

① Align Components:

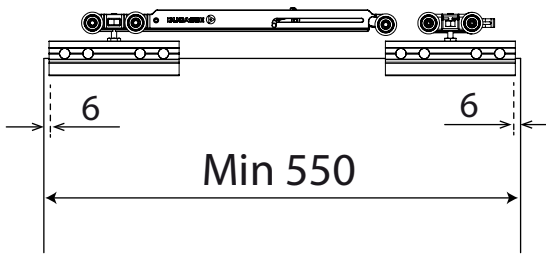

② Charge Easy Soft Piston:

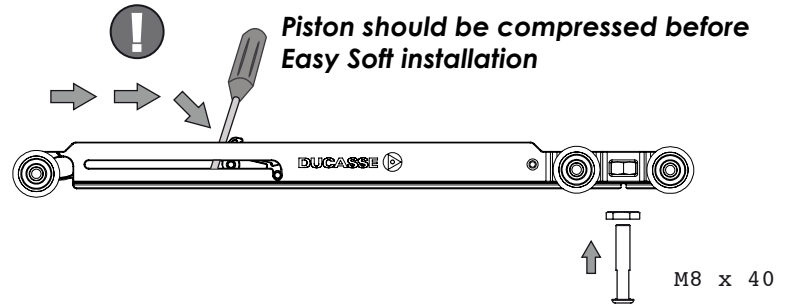

③ Install Carriers and Piston in Track

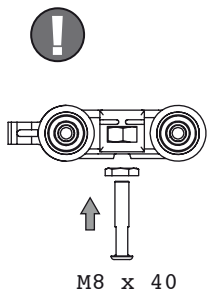

④ Install Track:

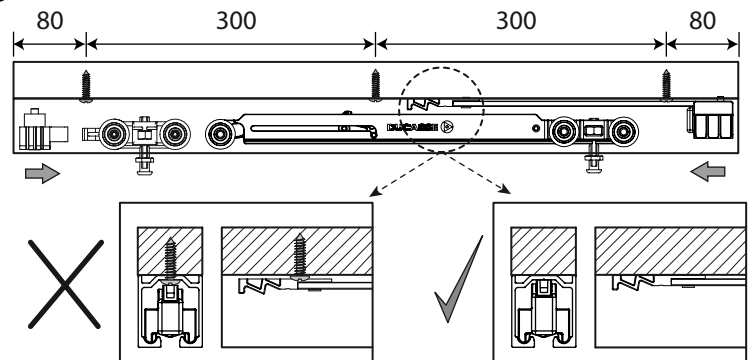

Countersink track fasteners over the EasySoft activator to avoid interference with the activator arm

⑤ Install Bottom Roller Guide:

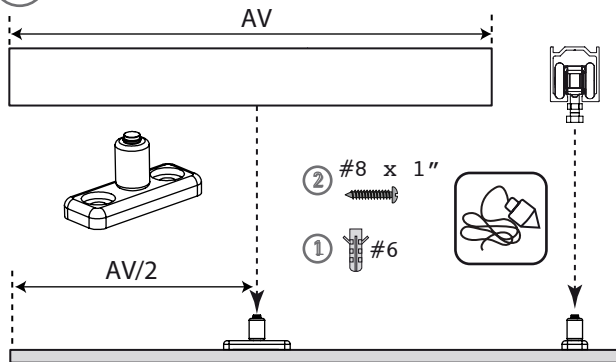

Use plumb line to determine exact center location

Install Door Brackets:

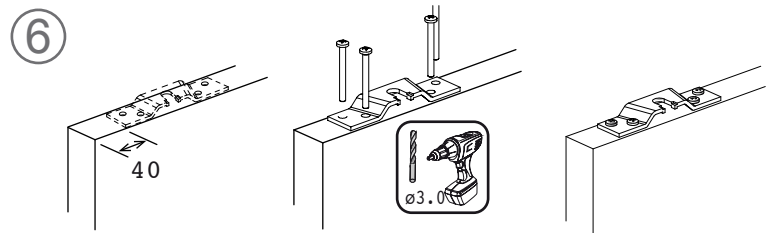

Pre-installed on sliding doors by Element Designs

7 Door Installation:

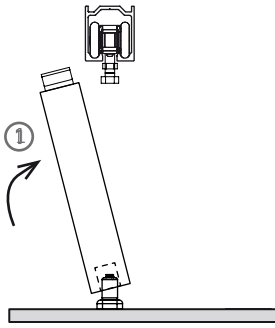

8 Lock Carriers In Place:

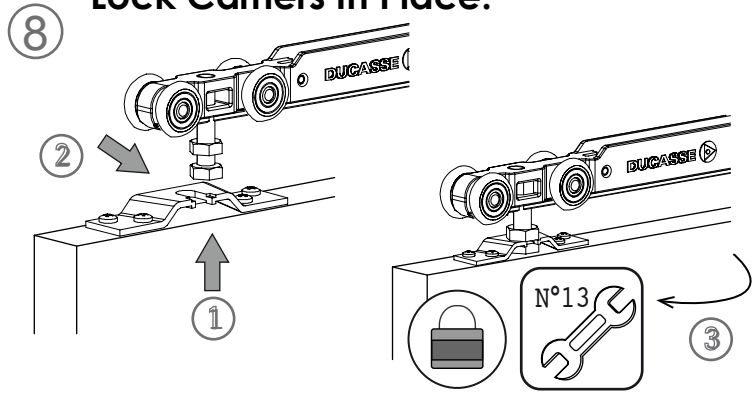

Carriers have 6mm of height adjustment

Position Door Stop:

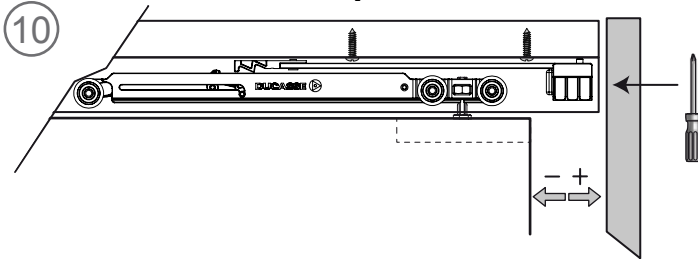

Secure Door Stop and Lock In Place:

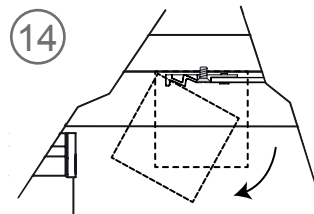
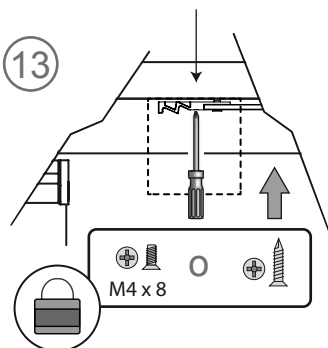
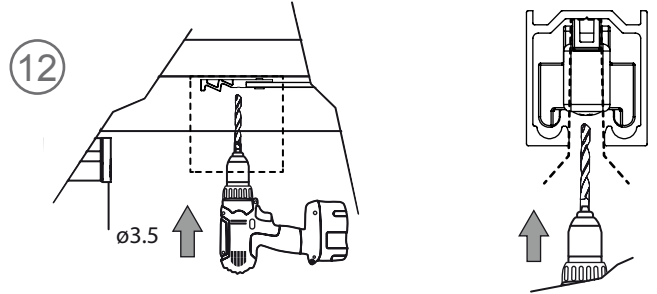
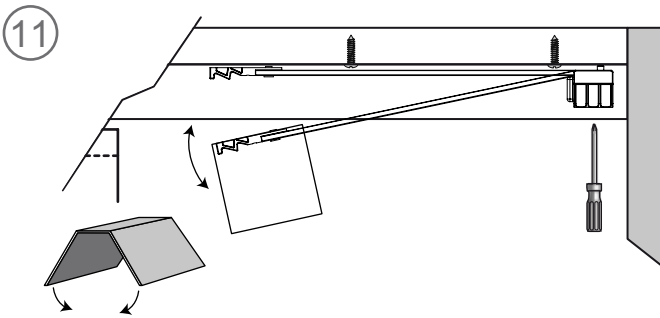



# DN 80 CF Sliding Door System

Quote  Order

Company: \_\_\_\_\_  
 Contact Name: \_\_\_\_\_  
 Address: \_\_\_\_\_  
 City / State / Zip: \_\_\_\_\_  
 Phone #: \_\_\_\_\_  
 Fax #: \_\_\_\_\_  
 Email: \_\_\_\_\_

**Email (or fax) form to your authorized distributor:**

Authorized Distributor: \_\_\_\_\_  
 Branch Location: \_\_\_\_\_  
 Email / Fax: \_\_\_\_\_



Ph: (877) 332-3396 Fx: (704) 332-3267  
 www.element-designs.com orders@element-designs.com

Project Name: \_\_\_\_\_  
 Date: \_\_\_\_\_ PO #: \_\_\_\_\_

## ① Door Type

• Aluminum Frame:

- AF002  AF003
- AF004  AF005
- AF006\*  AF007
- AF009  AF010\*

\*AF006 & AF010 available ONLY with opaque Backpainted Glass inserts

- 18mm PARAPAN®
- Color: \_\_\_\_\_

## ② Profile Finish

(Aluminum Frame doors only)

• Anodized Finish

- Natural Anodized
- Brushed Stainless
- Chrome (AF003 & AF010 ONLY)
- Arctic Gold (AF003 ONLY)

• Powder Coat Finish

- Oil Rubbed Bronze
- White  Black

## ③ Opening Info

Dimensions of space where doors will be installed, used to calculate door dimensions. Use smallest height to calculate door height.

Height (Left): \_\_\_\_\_  
 Height (Center): \_\_\_\_\_  
 Height (Right): \_\_\_\_\_  
 Width: \_\_\_\_\_

## ④ Insert Type (select one)

• Standard Glass Inserts:

- Satin (Acid Etched)  Listral D  Reeded (Vertical)
- Clear  Austral  Reeded (Horizontal)
- Smoked Grey  Master Carre
- Low-Iron Clear  Low-Iron Satin (Acid Etched)

• Backpainted Glass Inserts:

Finish (select one):

- Gloss  Matte

Color (select one):

- White  Scarlett  Silver
- Black  Olive  Bronze
- Sand  Mocha  Charcoal
- Non-Standard Color: \_\_\_\_\_
- Custom Color\*: \_\_\_\_\_

\*Custom Color match approval & fee applies. Contact Element Designs for details.

\*\*Backpainted glass has a light gray backer, unless otherwise specified

• 3form® Resin Inserts:

- Pattern: \_\_\_\_\_

• Parapan® High Gloss Inserts:

- Color: \_\_\_\_\_

• Metallic Inserts:

- Aluminum Laminate  Stainless Lam. (Vertical)
- Platinum Ice Acrylic  Stainless Lam. (Horizontal)

• Custom Etch:

- Positive Etch
- Negative Etch

\*Art work must be supplied, subject to set up fee. Contact Element Designs for details.

- NO INSERT *all inserts are 5/32" (4mm) thick*

All glass is tempered safety glass & will not have etched tempered logo unless otherwise specified at time of order. Refer to local building codes.

## ⑥ Sliding Hardware Selection

See DN 80 CF technical manual for hardware specifications

### A. Installation (select one)

- Interior Opening - Single track
- Interior Opening - Double track
- Barn Door (requires wall mount brackets for track, ONLY single track, ONE plane of travel)

### B. Planes of Travel & Number of Doors

- 1 Plane - 1 Door
- 1 Plane - 2 Doors
- 2 Planes - 2 Doors
- 2 Planes - 3 Doors
- Other (Please Specify details in Special Instructions)

### C. Fascia Cover Finish

- Natural Anodized  Oil Rubbed Bronze
- Brushed Stainless not available  White  Black

### D. Soft Close\*

- Do not include
- ONE mechanism per door - LEFT SIDE
- ONE mechanism per door - RIGHT SIDE
- TWO mechanisms per door - LEFT AND RIGHT

\*Min door width of 21.65" for one mechanism, 34.25" for two mechanisms

One Carrier Kit per door will be included unless other wise noted. Lateral door bracket will be pre installed

## ⑤ Decorative Hardware

— Natural Anodized — | Brushed Stainless & ORB | — Various Finishes —

- |                               |                                 |                                    |                                   |
|-------------------------------|---------------------------------|------------------------------------|-----------------------------------|
| Knobs                         | Bar Pulls                       | Bar Pulls                          | Finger Pulls                      |
| <input type="checkbox"/> K001 | <input type="checkbox"/> P1-127 | <input type="checkbox"/> P1-76S    | <input type="checkbox"/> P2-42    |
| <input type="checkbox"/> K005 | <input type="checkbox"/> P1-190 | <input type="checkbox"/> P1-192S   | <input type="checkbox"/> P2-42S   |
| <input type="checkbox"/> K006 | <input type="checkbox"/> P1-250 | <input type="checkbox"/> P1-320S   | <input type="checkbox"/> P2-42ORB |
| <input type="checkbox"/> K007 | <input type="checkbox"/> P1-380 | <input type="checkbox"/> P1-76ORB  | <input type="checkbox"/> Other    |
| <input type="checkbox"/> K008 | <input type="checkbox"/> P1-640 | <input type="checkbox"/> P1-192ORB |                                   |
| <input type="checkbox"/> K009 | <input type="checkbox"/> P1-880 | <input type="checkbox"/> P1-320ORB |                                   |

QTY: \_\_\_\_\_  Drill for handle holes (Must specify handle location on pg 2)

Item	Qty	Dimensions (See pg 2)		in OR mm	Divider Rails		Element Designs Use Only	
		Width	Height		(See Page 2)	Qty	Price	Ext. Price
1					<input type="checkbox"/> yes			
2					<input type="checkbox"/> yes			
3					<input type="checkbox"/> yes			
Special Instructions:							Hardware :	
							Subtotal :	
							Shipping :	
							TOTAL :	

**DN 80 CF Sliding Door System**

Quote  Order

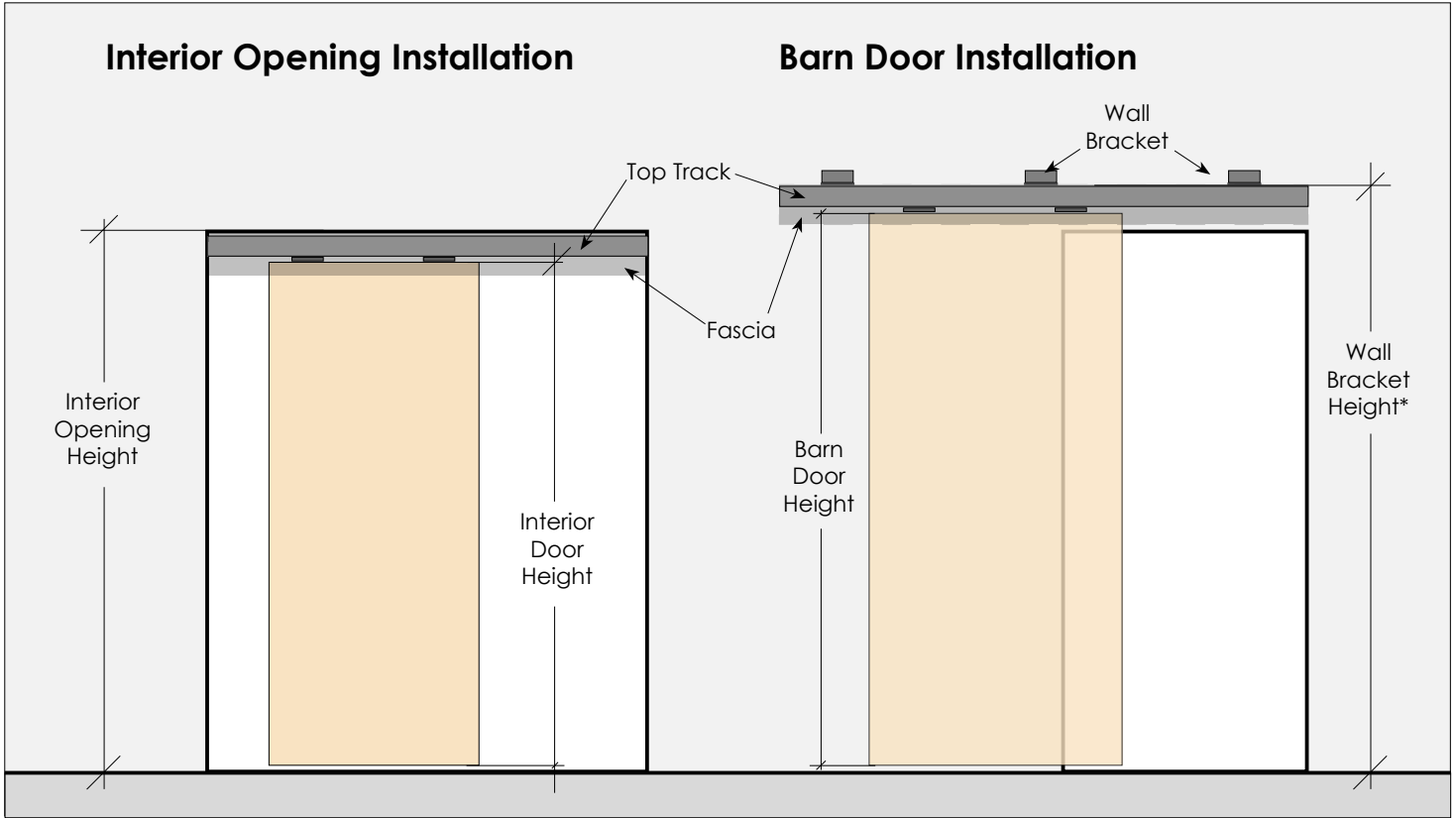

**Door Dimension Calculations:**

**Interior Opening Installation:**

Interior Door Height = Opening Height - 66mm  
 Door Width = (Opening width ÷ # of doors) + (profile width\* ÷ 2)  
 \*See Element Designs catalog for profile width dimensions

**Barn Door Installation:**

Barn Door Height = Wall Bracket Height\* - 66mm  
 \*Wall Bracket Height measured from the BOTTOM of the bracket

**Hardware Dimensions:**

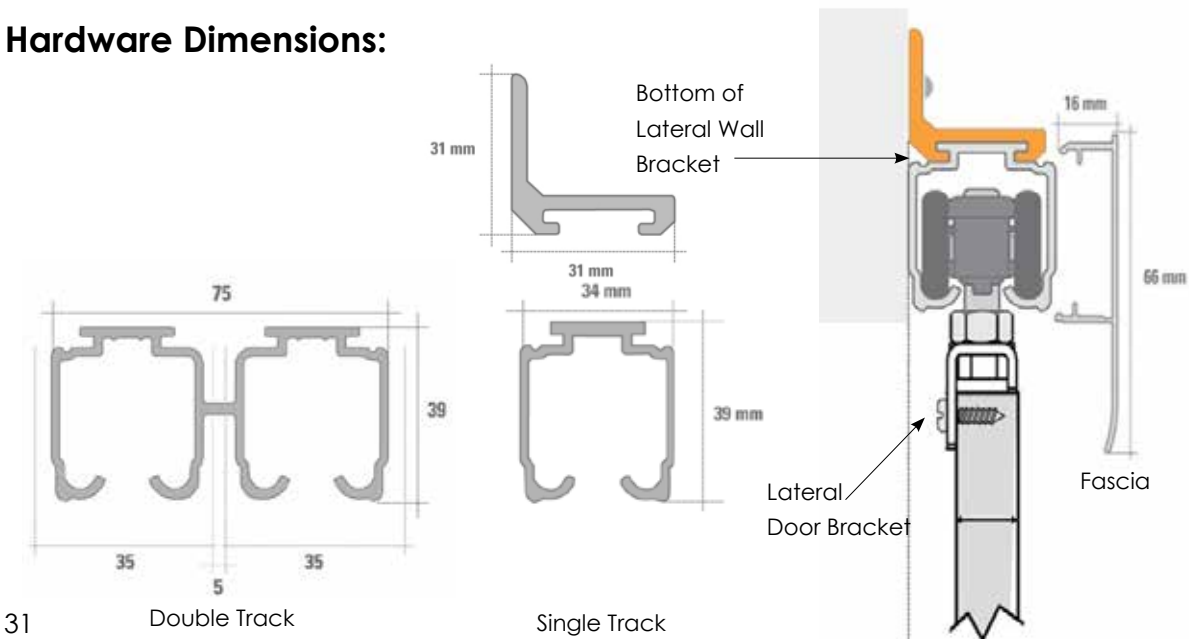



# DN 80 CF Sliding Door System

Quote  Order

## Divider Rail Inserts & Locations:

\*ONLY available with AF003, AF005, AF007, & AF009. Width = 3/4"

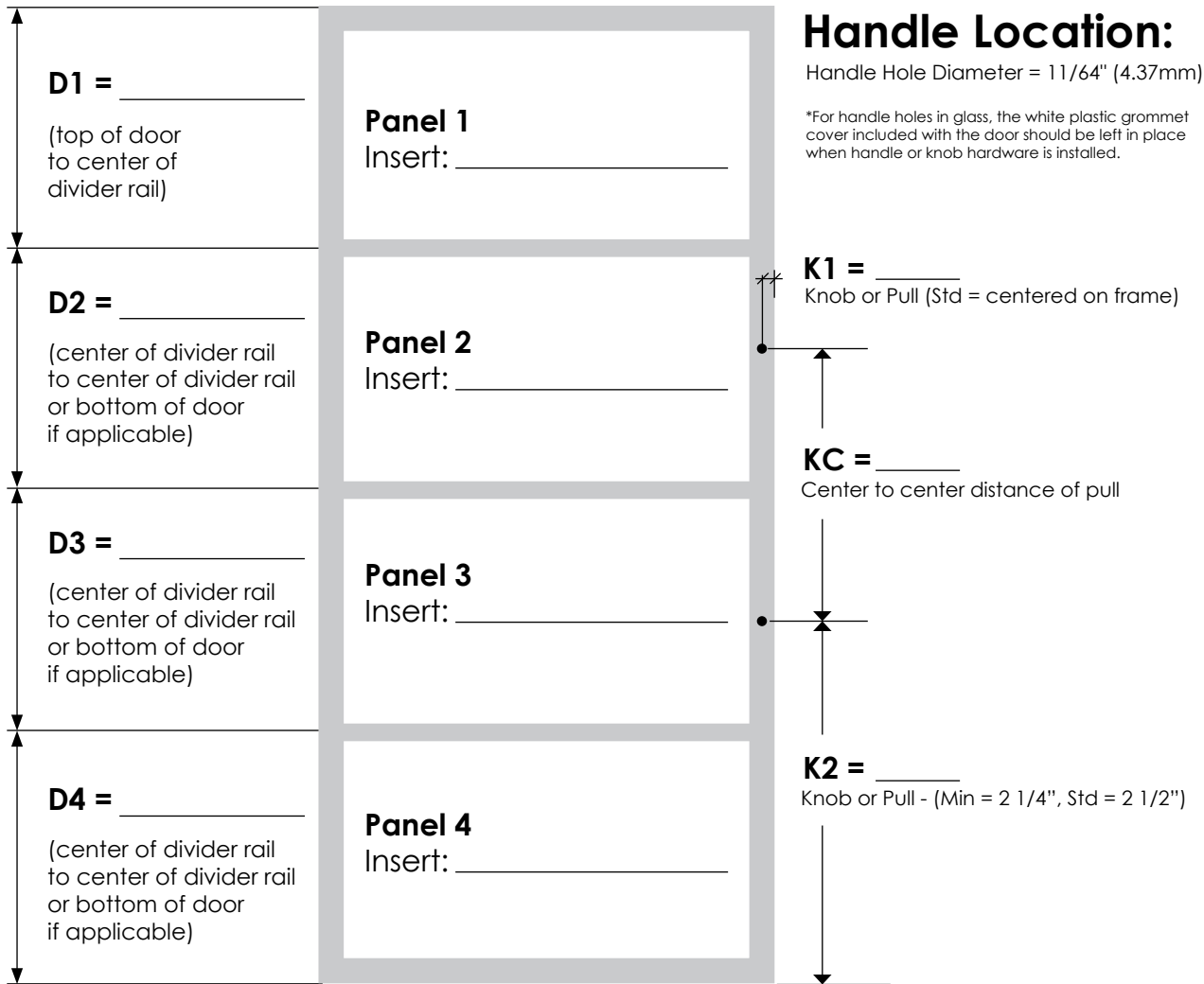

for additional information or customer support please call: (877) 332-3396





## CD 30 CX

### Design Guidelines:

- Small Sliding System, top and bottom track
- Single or by-pass sliding doors, with surface mount or inset track. Single overlay track available as well.
- Reference Sliding Systems At A Glance for maximum door dimensions
- Doors weighing up to 66 lbs

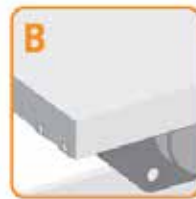
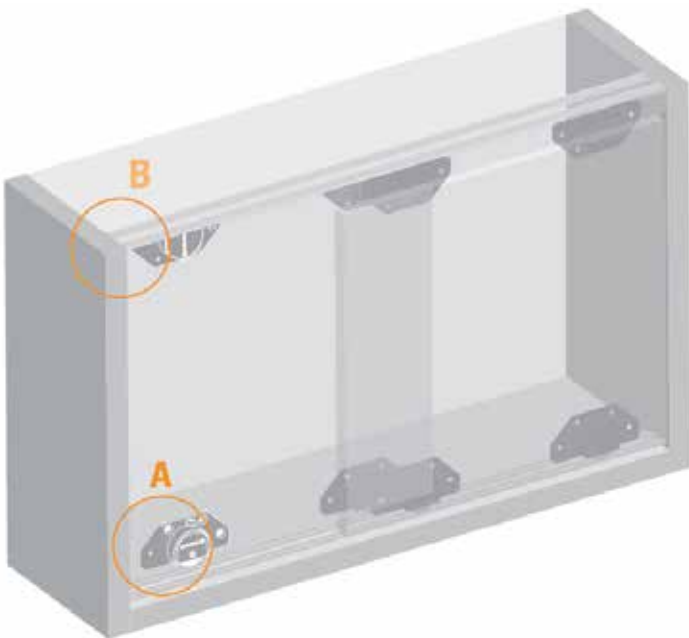

Small Door Carriers  
(4 per door - preinstalled)



Inset Track



AF002 Profile, White Gloss Backpainted Glass



AF004 Profile, Bear Grass 3Form (Upper)  
AF006 Profile, Olive Gloss Backpainted Glass (Lower)



AF004 Profile, White Matte Backpainted Glass

**Application Type:** SMALL sliding door applications (cabinets, furniture, closets / wardrobes)

**Tracks & Guides:** Surface mount or inset floor track and guide

**Frame height minimum:** 35mm (1.38") - CANNOT USE WITH NARROW FRAME DOORS AF001 and AF008

**Planes of Travel:** multiple doors on multiple planes of travel

## FEATURES AND BENEFITS

Includes brakes for lower track.

Easy adjustment and smooth movement.

Spring loaded carriers and guides prevent the door from jumping the track.

Spring lock mechanism allows for easy installation and removal of th door.

Flush mount carrier installation reduces the space/ gap between the doors.

## DESIGN GUIDELINES

**Door weight max:** 30kg (~66 lbs)

Refer to online door weight calculator to determine door weight: <http://www.element-designs.com/support/>

**Recommended Door height max:** 96" (contact Element Designs for taller dimensions)

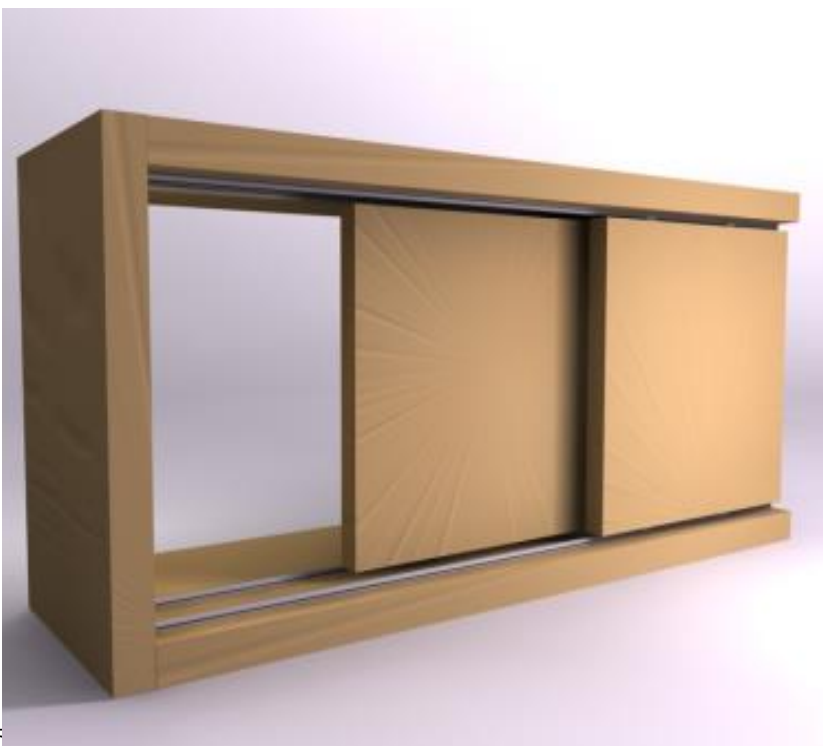

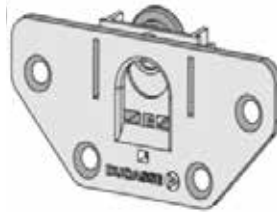
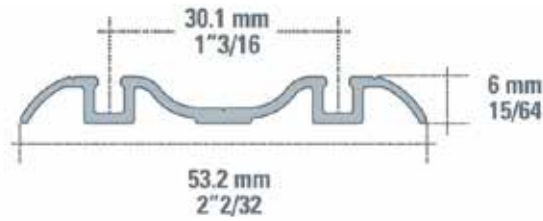
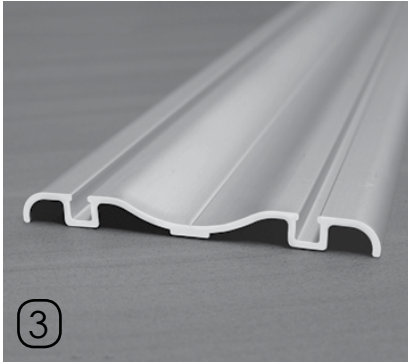
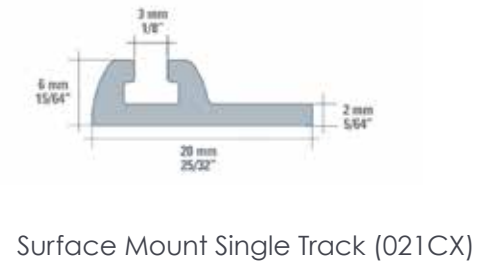
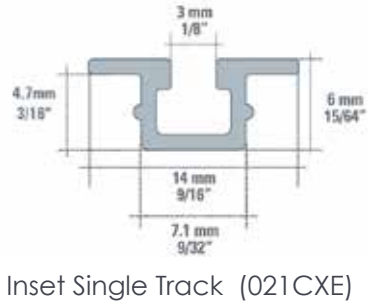
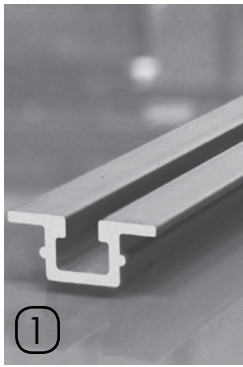

Top Guide (Pre-installed)

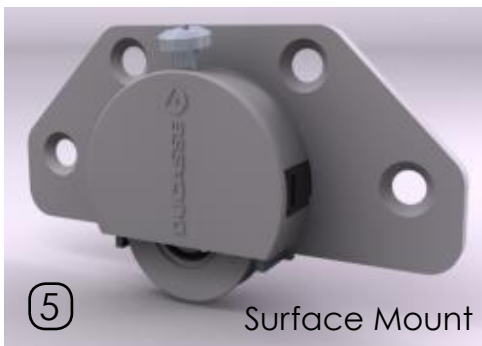

Surface Mount



Flush Mount

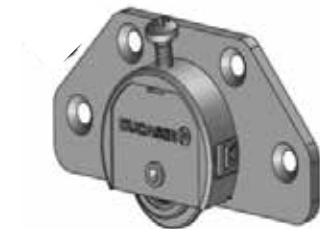

Lower Carrier (Pre-installed)



Brake

- 1) Inset Single Track (021CXE)
- 2) Surface Mount Single Track (021CX)
- 3) Surface Mount Double Track (021CXD)
- 4) Top Guide
- 5) Lower Carrier
- 6) Brake

**Surface Mount Track:**

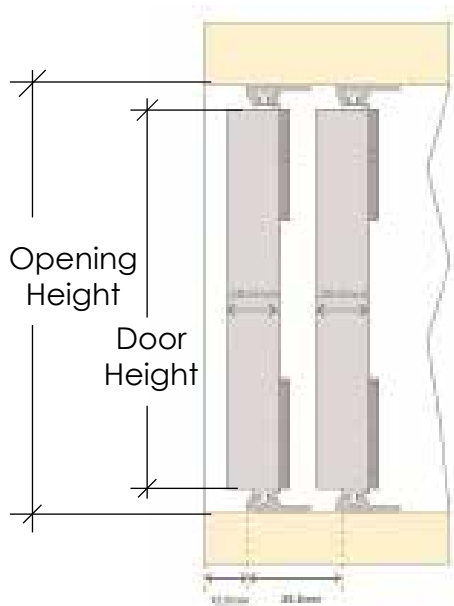

Door Height = Opening Height - 18mm

**Inset Track:**

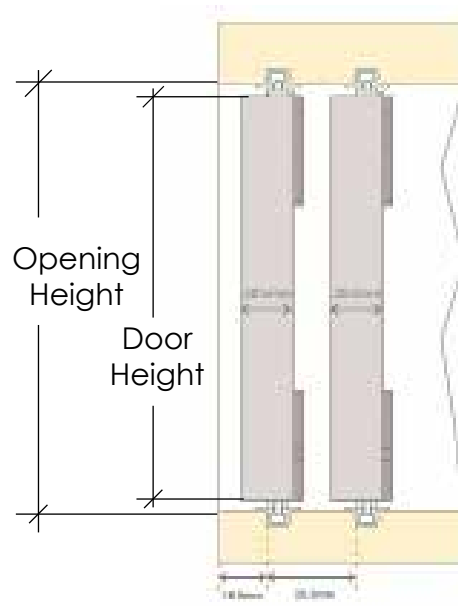

Door Height = Opening Height - 8mm

Door Width = (Opening width ÷ # of doors) + (profile width\* ÷ 2)

\*Profile Width:

- |                       |                       |                       |                         |                       |
|-----------------------|-----------------------|-----------------------|-------------------------|-----------------------|
| AF002 = 2 1/8" (54mm) | AF004 = 1 3/4" (45mm) | AF006 = 1 3/4" (45mm) | AF009 = 2 1/2" (63.5mm) | AF011 = 2 1/4" (57mm) |
| AF003 = 2 1/8" (54mm) | AF005 = 1 3/4" (45mm) | AF007 = 2 3/4" (70mm) | AF010 = 2 1/8" (54mm)   |                       |

Install brakes in track prior to track installation.

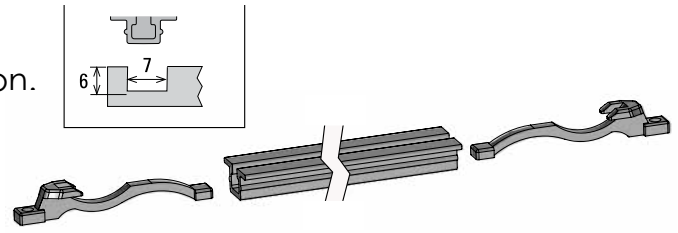

Install carriers (pre-installed in Element Designs' doors)

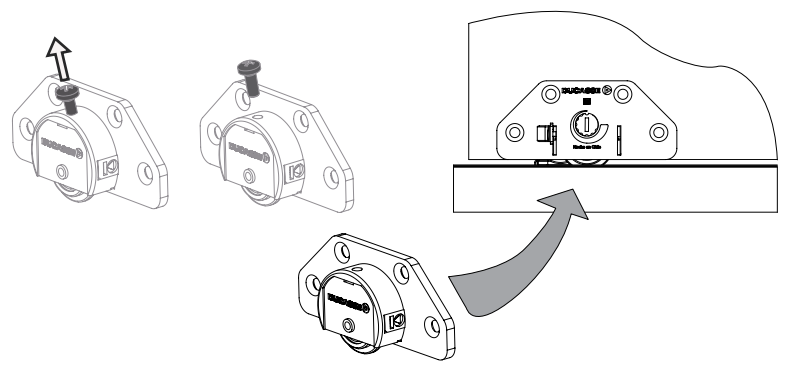
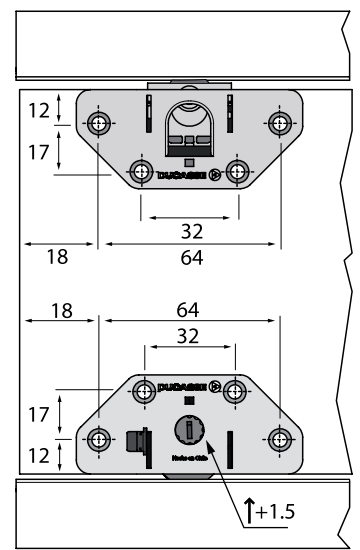
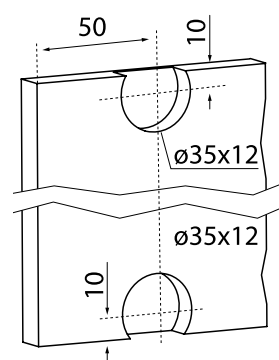
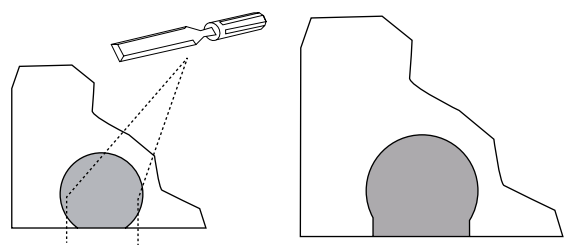

Unlock lower carrier prior to installing door in track. Lock carrier when doors are in place.

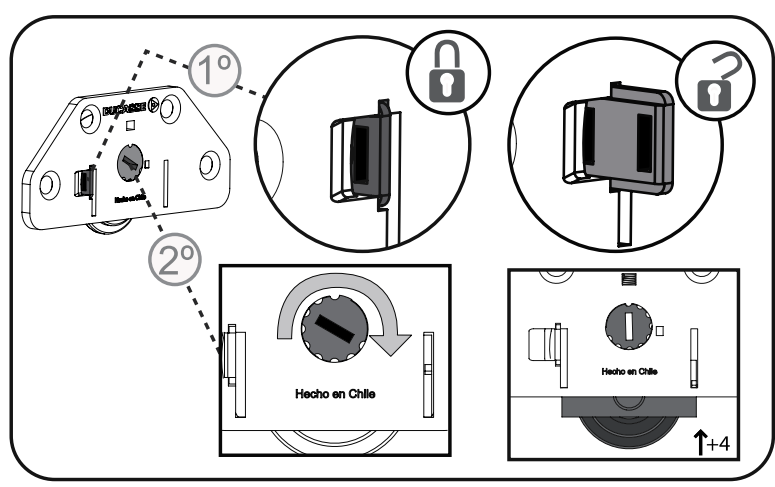

Install brakes in track prior to track installation.

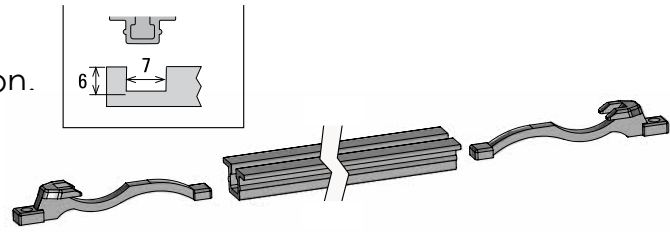

Install carriers

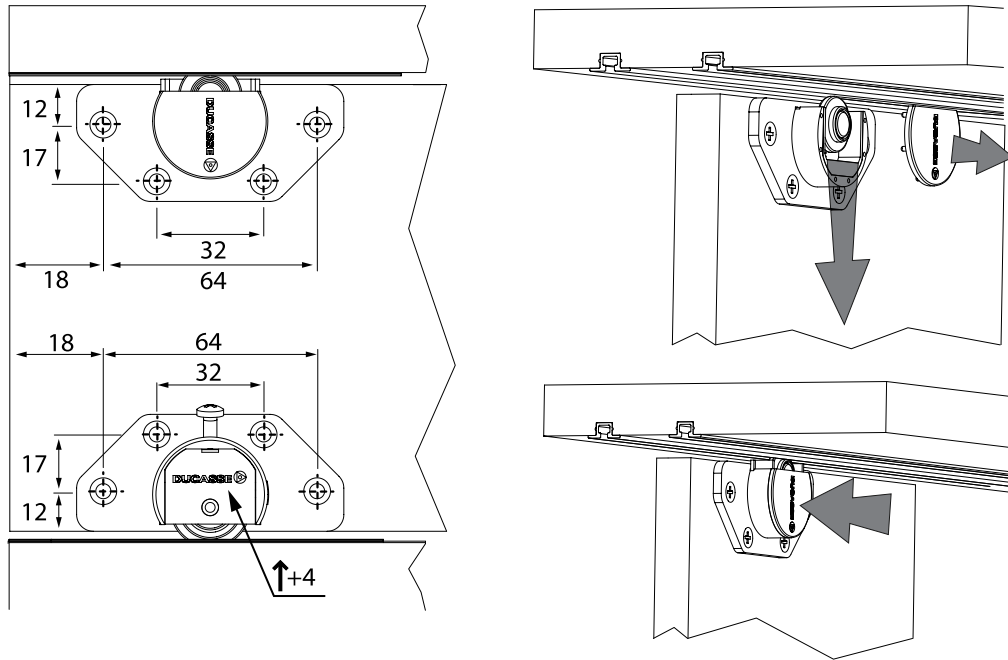

Unlock lower carrier prior to installing door in track. Lock carrier when doors are in place.

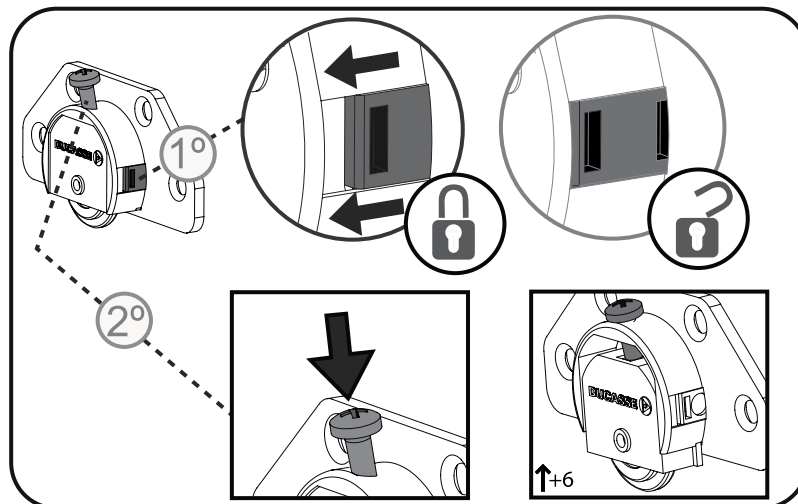



www.element-designs.com

# CD 30 CX Sliding Door System Quote Order

Bottom Mount - 6 inch Door - Maximum 80 lb / 44 lbs. per door

Company: \_\_\_\_\_  
 Contact Name: \_\_\_\_\_  
 Address: \_\_\_\_\_  
 City / State / Zip: \_\_\_\_\_  
 Phone #: \_\_\_\_\_  
 Fax #: \_\_\_\_\_  
 Email: \_\_\_\_\_

Email (or fax) form to your authorized distributor:

Authorized Distributor: \_\_\_\_\_  
 Branch Location: \_\_\_\_\_  
 Email / Fax: \_\_\_\_\_



Tel: (877) 888-8884 Tel: (760) 382-8887  
 www.element-designs.com orders@element-designs.com

Project Name: \_\_\_\_\_  
 Date: \_\_\_\_\_ PO #: \_\_\_\_\_

### 1 Door Type

- **Aluminum Frame:**
  - AF002  AF003
  - AF004  AF005
  - AF006\*  AF007
  - AF009  AF010\*
  - AF011
- \*AF006 & AF010 available ONLY with opaque backpainted Glass Insert
- **18mm PARAPAN®**
- Color: \_\_\_\_\_

### 2 Profile Finish

- (Aluminum frame doors only)
- **Anodized Finish**
    - Natural Anodized
    - Brushed Stainless
    - Chrome (year to year only)
    - Arctic Gold (patented)
  - **Powder Coat Finish**
    - Oil Rubbed Bronze
    - White  Black

### 3 Opening Info

Dimensions of space where door will be installed, used to calculate door dimensions. Use smallest height to calculate door height.

Height (Left): \_\_\_\_\_  
 Height (Center): \_\_\_\_\_  
 Height (Right): \_\_\_\_\_  
 Width: \_\_\_\_\_

### 4 Insert Type (select one)

- **Standard Glass Insert:**
  - Satin (polished)  Litoral D  Reeded (patent)
  - Clear  Austral  Reeded (patent)
  - Smoked Grey  Master Came
  - Low Iron Clear  Low Iron Satin (polished)
- **Backpainted Glass Insert:**  
 Finish (select one):  
 Glass  Matte  
 Paint Color (select one):  
 White  Scarlett  Silver  
 Black  Olive  Bronze  
 Sand  Mocha  Charcoal  
 Non-Standard Color: \_\_\_\_\_  
 Custom Color\*: \_\_\_\_\_

\*Custom Color match approval & fee applies. Contact Element Design for details.  
 \*Backpainted glass has a light grey border, unless otherwise specified

- **3form® Resin Insert:**  
 Pattern: \_\_\_\_\_
- **PARAPAN® High Glass Insert:**  
 Color: \_\_\_\_\_

- **Metallic Insert:**
  - Aluminum Laminate  Stainless Lam. (patent)
  - Platinum Ice Acrylic  Stainless Lam. (patent)
- **Custom Etch:**
  - Positive Etch  Negative Etch

all inserts are 3/8" (9mm) thick  NO INSERT

All glass is tempered safety glass with no heat-treated tempered top edge or reveals specified or listed order. Refer to local building codes.

### 5 Sliding Hardware Selection

See CD 30 CX technical manual for hardware specifications

#### A. Floor Track (select one)

- Inset - single only
- Surface Mount - single only
- Surface Mount - double only

#### B. Planes of Travel & Number of Doors

- 1 Plane - 1 Door
- 1 Plane - 2 Doors
- 2 Planes - 2 Doors
- 2 Planes - 3 Doors
- 2 Planes - 4 Doors
- Other (Please specify details in special instruction)

#### C. Track Finish (Select one)

- Natural Anodized  Oil Rubbed Bronze
- White  Black

One Carrier Kit per door will be included and preinstalled on each door, unless otherwise noted.

### 6 Decorative Hardware & Handles

- Drill for handle holes (Please specify handle location on pg 2)
- | No/Lost/Anodized              |                                 | Brushed Stainless & Oil            |           | Polished Chrome                   |              |
|-------------------------------|---------------------------------|------------------------------------|-----------|-----------------------------------|--------------|
| Knobs                         | Bar Pulls                       | Bar Pulls                          | Bar Pulls | Finger Pulls                      | Finger Pulls |
| <input type="checkbox"/> KD01 | <input type="checkbox"/> P1-127 | <input type="checkbox"/> P1-765    |           | <input type="checkbox"/> P2-42    |              |
| <input type="checkbox"/> KD05 | <input type="checkbox"/> P1-190 | <input type="checkbox"/> P1-1925   |           | <input type="checkbox"/> P2-42S   |              |
| <input type="checkbox"/> KD06 | <input type="checkbox"/> P1-250 | <input type="checkbox"/> P1-3205   |           | <input type="checkbox"/> P2-42CRS |              |
| <input type="checkbox"/> KD07 | <input type="checkbox"/> P1-380 | <input type="checkbox"/> P1-760RB  |           |                                   |              |
| <input type="checkbox"/> KD08 | <input type="checkbox"/> P1-640 | <input type="checkbox"/> P1-1920RB |           |                                   |              |
| <input type="checkbox"/> KD09 | <input type="checkbox"/> P1-880 | <input type="checkbox"/> P1-3200RB |           | <input type="checkbox"/> Other    |              |
- QTY: \_\_\_\_\_

Item	Qty	Door Dimensions (See page 2)		in or mm	Divider Rails		Element Design Use Only	
		Width	Height		As Req'd	Qty	Price	Est. Price
1					<input type="checkbox"/> yes <input type="checkbox"/> no			
2					<input type="checkbox"/> yes <input type="checkbox"/> no			
3					<input type="checkbox"/> yes <input type="checkbox"/> no			

Special Instructions: \_\_\_\_\_

Knobs/Pulls: \_\_\_\_\_  
 Hardware: \_\_\_\_\_  
 Shipping: \_\_\_\_\_  
**TOTAL:** \_\_\_\_\_





# CD 30 CX Sliding Door System

Quote  Order

Bottom Rolling - Inset Doors - Maximum 80 kg / 44 lbs. per door

## Door Dimension Calculations:

### Surface Mount Track:

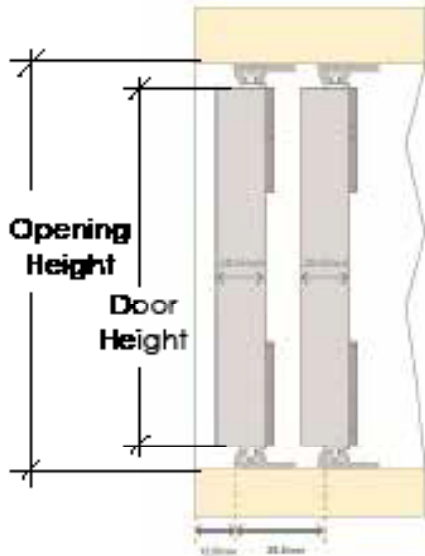

Door Height = Opening Height - 18mm

### Inset Track:

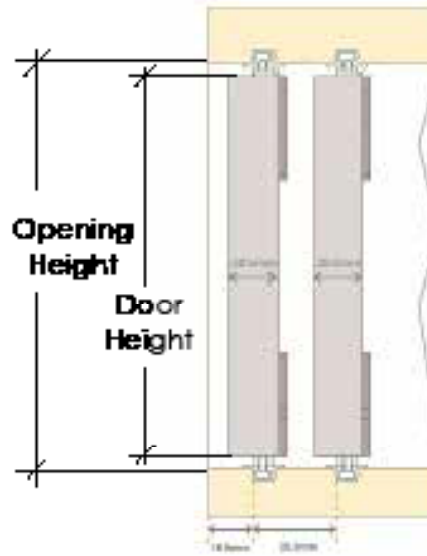

Door Height = Opening Height - 8mm

Door Width = [Opening width ÷ # of doors] + (profile width ÷ 2)

Profile Width: AFD02 = 2 1/8" (54mm)    ARD4 = 1 3/4" (45mm)    AFD06 = 1 3/4" (45mm)    AFD09 = 2 1/2" (63.5mm)    AFD11 = 2 1/4" (57mm)  
 AFD03 = 2 1/8" (54mm)    ARD5 = 1 3/4" (45mm)    AFD07 = 2 3/4" (70mm)    AFD10 = 2 1/8" (54mm)

## Divider Rail Inserts & Locations:

Divider Rails ONLY available with AFD03, AFD05, AFD07, & AFD09 - Rail width = 3/4"

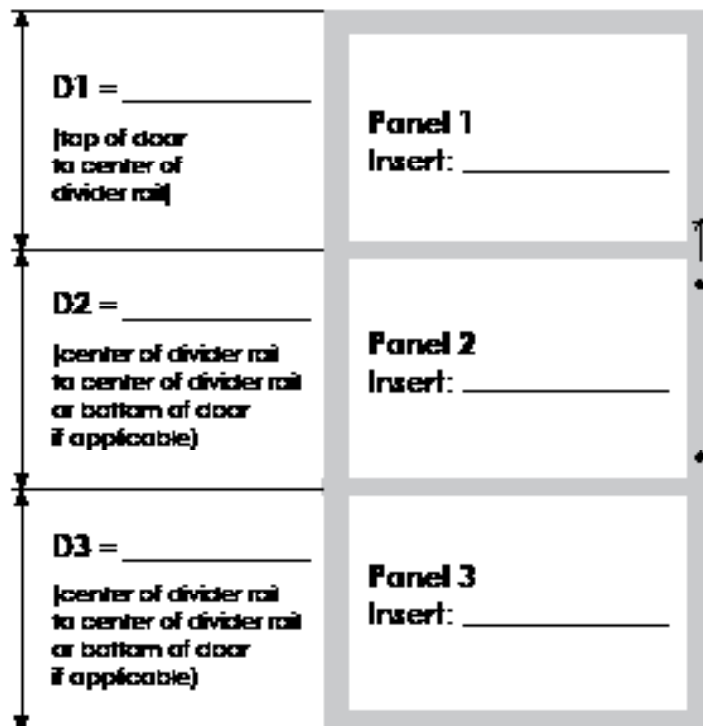

### Handle Location:

Rail Hole Diameter = 1 1/4" (31.7mm)

\*For handle holes in glass, the white plastic general cover included with the door should be left in place when handle or knob hardware is installed.

**K1 =** \_\_\_\_\_  
Knob or Pull  
(Std = centered on frame)

**KC =** \_\_\_\_\_  
Center to center of Pull

**K2 =** \_\_\_\_\_  
Knob or Pull  
(Min = 2 1/4", Std = 2 1/2")

### Hardware Dimensions:

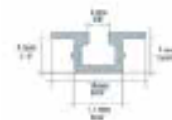

Inset Track (CXE)



Surface Mount Track Double (CXD)



Surface Mount Track Single (CX)

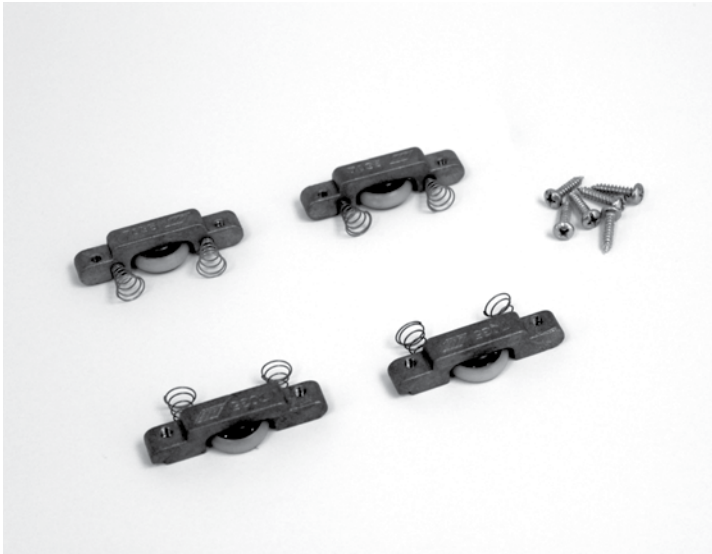

# SH 7035

**Design Guidelines:**

- Small Sliding System, top and bottom track
- Multiple doors per system, inset track
- Reference Sliding Systems At A Glance for maximum door dimensions
- Doors weighing up to 33 lbs

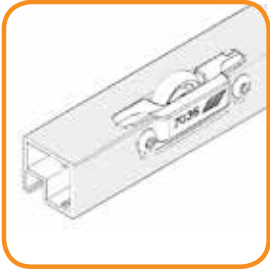
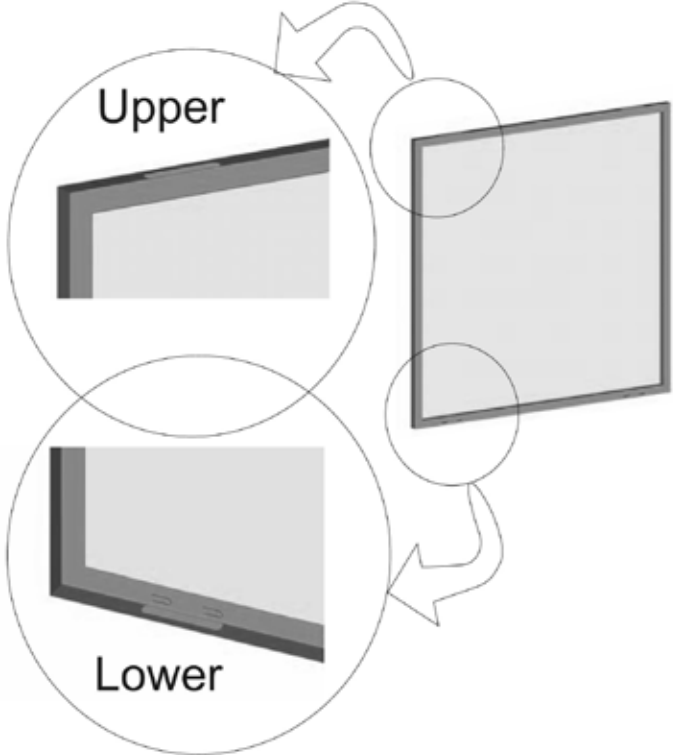

Small Door Carriers  
(4 per door - preinstalled)

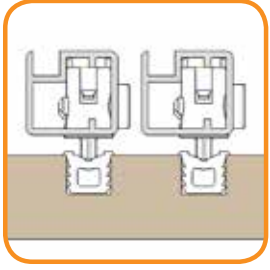

Inset Track  
Up to 140"



AF004 Profile, ORB Finish, Quattro Carbon 3Form

Image courtesy of California Closets. All rights reserved.



AF001 Profile, White Matte Backpainted Glass

**Application Type:** SMALL sliding door applications (cabinets, furniture, closets / wardrobes)

**Tracks & Guides:** inset top and bottom track

**Frame height minimum:** 20.5mm (.813")

**Planes of Travel:** multiple doors on multiple planes of travel

## ***FEATURES AND BENEFITS***

Easy adjustment and smooth movement.

Spring loaded carriers and guides prevent the door from jumping the track.

Flush mount carrier installation reduces the space/ gap between the doors.

## ***DESIGN GUIDELINES***

**Door weight max:** 15kg (~33 lbs)

Refer to online door weight calculator to determine door weight: <http://www.element-designs.com/support/>

**Recommended Door height max:** 48" (contact Element Designs for taller dimensions)

***NOT RECOMMENDED FOR USE WITH PARAPAN HIGH GLOSS SOLID SURFACE DOORS***

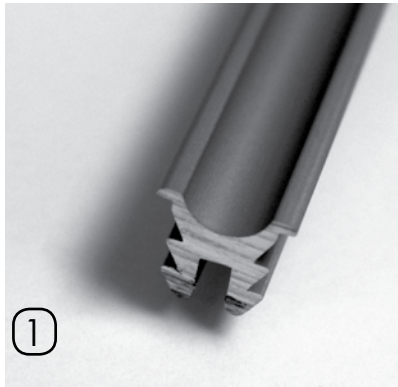

Inset Single Track (7035)

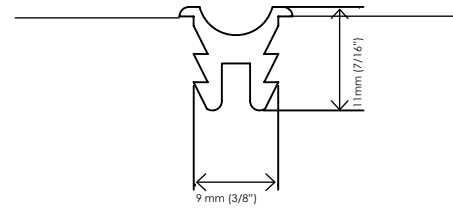

Small Door Carriers  
(pre-installed 4 per door)

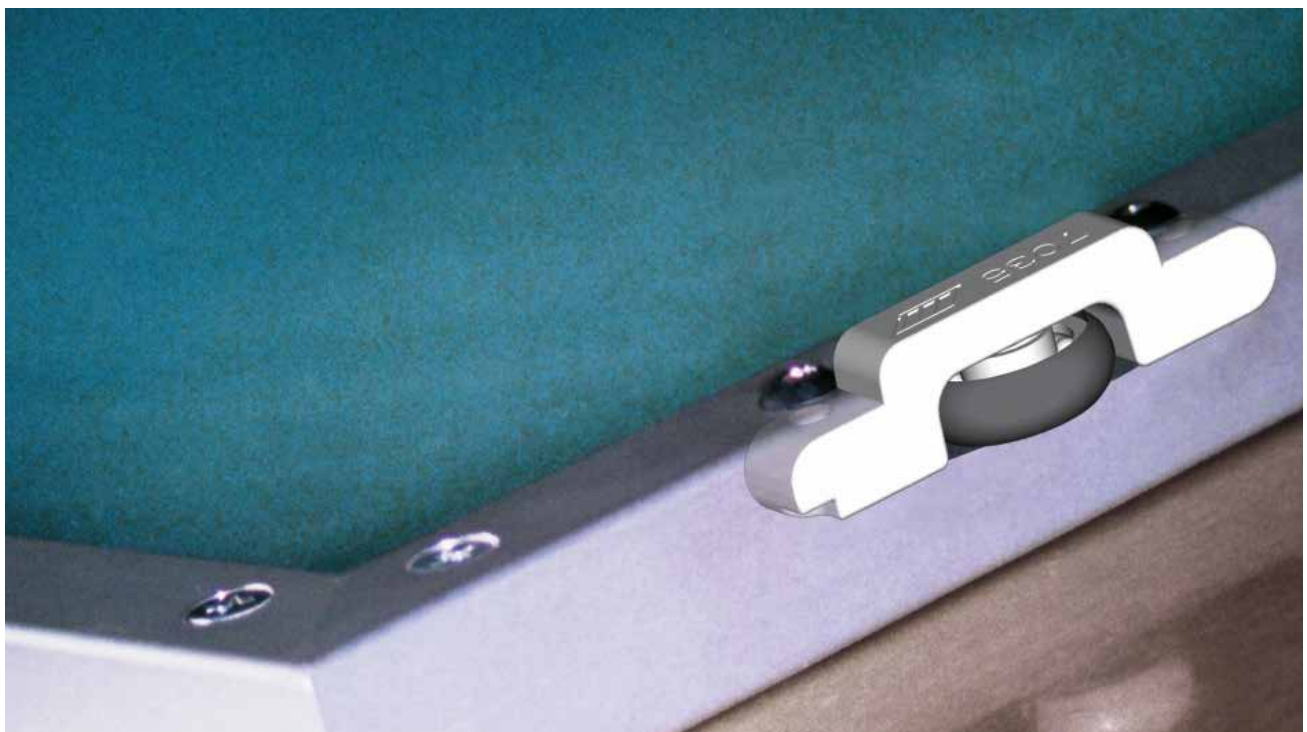

**Inset Track:**

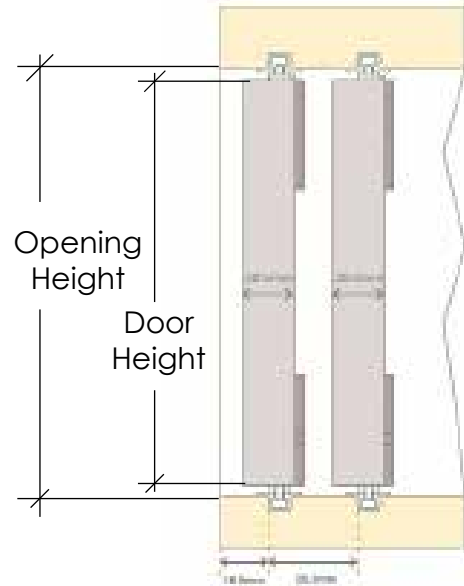

Door Height = Opening Height - 5mm

Door Height = Opening height - 5mm

Door Width = (Opening width + profile width\* ) / 2

*Profile Width: AF001 = 13/16" (20.5mm)	AF004 = 1 3/4" (45mm)	AF007 = 2 3/4" (70mm)	AF010 = 2 1/8" (54mm)
AF002 = 2 1/8" (54mm)	AF005 = 1 3/4" (45mm)	AF008 = 13/16" (20.5mm)	AF011 = 2 1/4" (57mm)
AF003 = 2 1/8" (54mm)	AF006 = 1 3/4" (45mm)	AF009 = 2 1/2" (63.5mm)	

**Track Positioning & Installation**

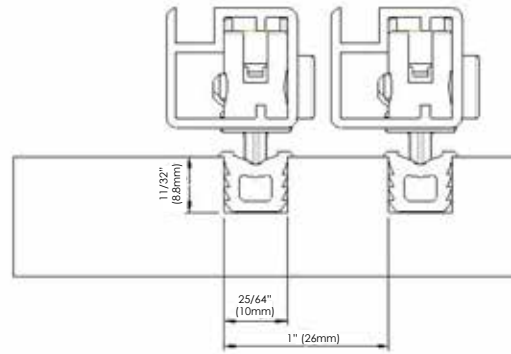

**Hardware Installation**

Element Designs will furnish pre-installed hardware in standard location

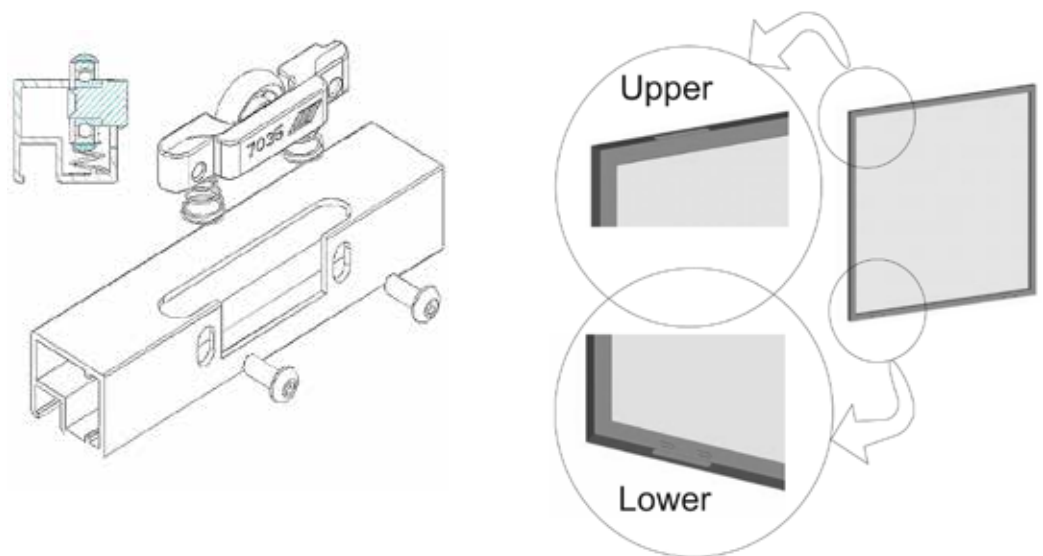

**Door Installation**

Install the back door first.

To install the door in track, insert the upper two rollers into the upper inner rail. Press the door upwards in order to go over the lower inner rail. The door will then fall into place in both upper and lower rails.

Repeat the installation with the front door.



# SH 7035 Sliding Door System

Top & Bottom Sliding - Small Doors - Maximum 14 lb / 6.5 lb. per door

Quote  Order

Company: \_\_\_\_\_  
 Contact Name: \_\_\_\_\_  
 Address: \_\_\_\_\_  
 City / State / Zip: \_\_\_\_\_  
 Phone #: \_\_\_\_\_  
 Fax #: \_\_\_\_\_  
 Email: \_\_\_\_\_

Email (or fax) form to your authorized distributor:

Authorized Distributor: \_\_\_\_\_  
 Branch Location: \_\_\_\_\_  
 Email / Fax: \_\_\_\_\_



For (877) 888-8891 For (760) 382-8867  
 www.element-designs.com orders@element-designs.com

Project Name: \_\_\_\_\_  
 Date: \_\_\_\_\_ PO #: \_\_\_\_\_

### 1 Door Type

- Aluminum Frame:**
- AF001  AF002
  - AF003  AF004
  - AF005  AF006\*
  - AF007  AF008
  - AF009  AF010\*
  - AF011

\*AF006 & AF010 available ONLY with opaque Backpainted Glass Inserts

### 2 Profile Finish

- Anodized Finish**  
 (Aluminum frame doors only)
- Natural Anodized
  - Brushed Stainless
  - Chrome (year & finish only)
  - Arctic Gold (patent only)
- Powder Coat Finish**
- Oil Rubbed Bronze
  - White  Black

### 3 Opening Info

Dimensions of space where doors will be installed, used to calculate door dimensions. Use smallest height to calculate door height.

Height (Left): \_\_\_\_\_  
 Height (Center): \_\_\_\_\_  
 Height (Right): \_\_\_\_\_  
 Width: \_\_\_\_\_

### 4 Insert Type (select one)

- Standard Glass Insert:**
- Satin (polished)  Lustral D  Reeded (vertical)
  - Clear  AUSTRIAL  Reeded (horizontal)
  - Smoked Grey  Master Came
  - Low Iron Clear  Low Iron Satin (polished)

#### Backpainted Glass Insert:

- Finish (select one):**
- Glass  Matte
- Paint Color (select one):**
- White  Scarlett  Silver
  - Black  Olive  Bronze
  - Sand  Mocha  Charcoal
  - Non-Standard Color: \_\_\_\_\_
  - Custom Color\*: \_\_\_\_\_

\*Custom Color work approval & fee applies. Contact Element Designs for details.  
 \*Backpainted glass is a light gray border, unless otherwise specified

#### Storm Resin Insert:

- Pattern: \_\_\_\_\_

#### PARAPAN High Glass Insert:

- Color: \_\_\_\_\_

#### Metallic Insert:

- Aluminum Laminate  Stainless Lam. (vertical)
- Platinum Ice Acrylic  Stainless Lam. (horizontal)

#### Custom Etch:

- Positive Etch  Negative Etch
- \*Artwork must be supplied, subject to art up fee. Contact Element Designs for details.

all inserts are 3/32" (mm) thick  NO INSERT

All glass is temperably glass with low-iron etched tempered edge unless otherwise specified or noted on order. Refer to local building codes.

### 5 Sliding Hardware Selection

See sliding door technical manual for hardware specifications

#### A. Track (select one)

- Inset - single only

#### B. Planes of Travel & Number of Doors

- 1 Plane - 1 Door
- 1 Plane - 2 Doors
- 2 Planes - 2 Doors
- 2 Planes - 3 Doors
- 2 Planes - 4 Doors
- Other (Please specify details in special instruction)

#### C. Track Finish (Select one)

- Natural Anodized  Oil Rubbed Bronze
- White  Black

Four door carriers per door will be included and preinstalled on each door.

### 6 Decorative Hardware & Handles

- Drill for handle holes (Must specify handle location on pg 2)

Noted/Anodized		Brushed Stainless & Oil		Polished Finish	
Knobs	Bar Pulls	Bar Pulls	Finger Pulls		
<input type="checkbox"/> K001	<input type="checkbox"/> P1-127	<input type="checkbox"/> P1-765	<input type="checkbox"/> P2-42		
<input type="checkbox"/> K005	<input type="checkbox"/> P1-190	<input type="checkbox"/> P1-1925	<input type="checkbox"/> P2-425		
<input type="checkbox"/> K006	<input type="checkbox"/> P1-250	<input type="checkbox"/> P1-3205	<input type="checkbox"/> P2-420 RB		
<input type="checkbox"/> K007	<input type="checkbox"/> P1-380	<input type="checkbox"/> P1-760 RB			
<input type="checkbox"/> K008	<input type="checkbox"/> P1-640	<input type="checkbox"/> P1-1920 RB			
<input type="checkbox"/> K009	<input type="checkbox"/> P1-880	<input type="checkbox"/> P1-3200 RB	<input type="checkbox"/> Other		

QTY: \_\_\_\_\_

Item	Qty	Door Dimensions (See page 2)		in or mm	Divider Rails		Element Designs Use Only	
		Width	Height		Use Handle	Qty	Price	Est. Price
1					<input type="checkbox"/> yes <input type="checkbox"/> no			
2					<input type="checkbox"/> yes <input type="checkbox"/> no			
3					<input type="checkbox"/> yes <input type="checkbox"/> no			

Special Instructions: \_\_\_\_\_

Knobs/Pulls : \_\_\_\_\_  
 Hardware : \_\_\_\_\_  
 Shipping : \_\_\_\_\_  
**TOTAL :** \_\_\_\_\_





www.element-designs.com

# SH 7035 Sliding Door System

Top & Bottom Rolling - Small Doors - Maximum 10 kg / 22 lbs. per door

Quote  Order

## Door Dimension Calculations:

### Inset Track:

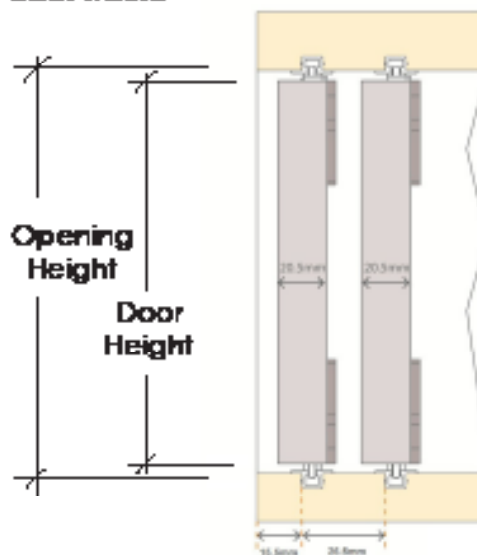

Door Height = Opening Height - 5mm

Door Width = (Opening width ÷ # of doors) + (profile width\* ÷ 2)

*Profile Width:	AFD01 = 3/4" (20.5mm)	AFD04 = 1 3/4" (45mm)	AFD07 = 2 3/4" (70mm)	AFD10 = 2 1/8" (54mm)
	AFD02 = 2 1/8" (54mm)	AFD05 = 1 3/4" (45mm)	AFD08 = 3/4" (20.5mm)	AFD11 = 2 1/4" (57mm)
	AFD03 = 2 1/8" (54mm)	AFD06 = 1 3/4" (45mm)	AFD09 = 2 1/2" (63.5mm)	

## Divider Rail Inserts & Locations:

Divider Rails ONLY available with AFD01, AFD03, AFD05, AFD07, & AFD09 - Rail width = 3/4"

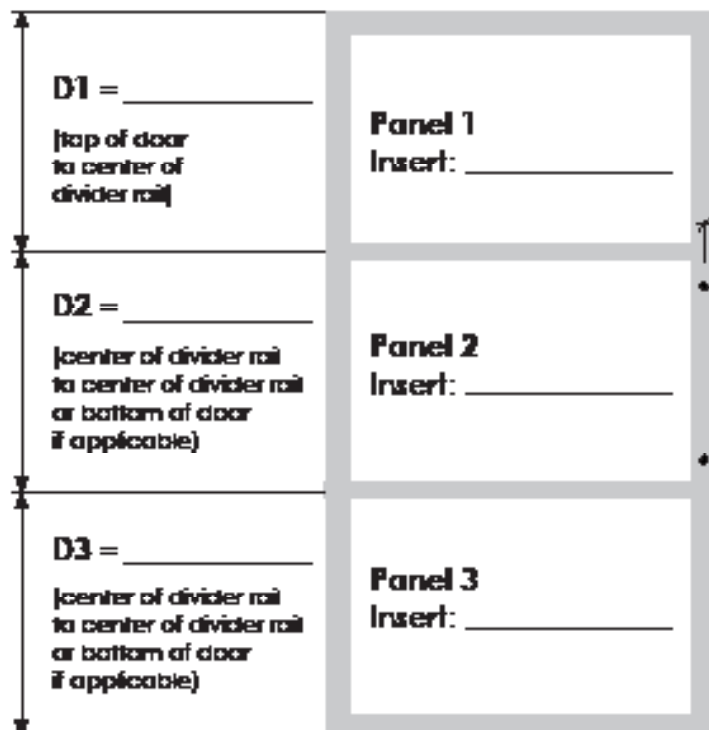

### Handle Location:

Rough Hole Diameter = 1 1/4" (32mm)  
 \*For handle hole in glass, the white plastic grommet cover included with the door should be left in place when handle or knob hardware is installed.

K1 = \_\_\_\_\_  
 Knob or Pull  
 (Std = centered on frame)

KC = \_\_\_\_\_  
 Center to center of Pull

K2 = \_\_\_\_\_  
 Knob or Pull  
 (Min = 2 1/4", Std = 2 1/2")

### Hardware Dimensions:

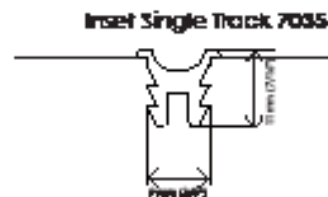

Element Designs' aluminum frame cabinet door products are covered by a limited liability warranty from defects in material and workmanship over the functional lifetime of the doors. The warranty includes any defects in the fabricated door size, boring locations, aluminum framing flaws outside of quality standards, and glass imperfections outside of quality standards. Element Designs also warrants its doors from deterioration, discoloring, degrading, or overall changing through the course of the product's lifetime. This warranty does not apply if, in the judgment of Element Designs, the product fails due to damage from shipment, handling, storage, accident, abuse or misuse, or if it has been used or maintained in a manner not conforming to product's care instructions, has been modified in any way, or has been defaced. Repair by anyone other than Element Designs or an approved agent voids this warranty. The maximum liability of Element Designs is the product purchase price.



Street Address:  
235 Crompton Street  
Charlotte, NC 28273

Mailing Address:  
P.O. Box 7747  
Charlotte, NC 28241

Ph: 877-332-3396  
Fx: 704-332-3267

[www.element-designs.com](http://www.element-designs.com)  
[info@element-designs.com](mailto:info@element-designs.com)

Proud member of:

